

JVC

SERVICE MANUAL

COMPACT COMPONENT MD SYSTEM

CA-MXS6MDR SP-MXS6MD

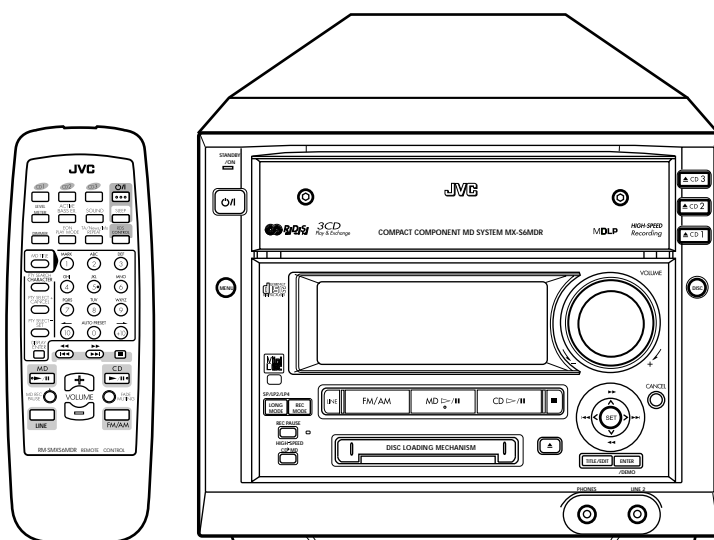

MDLP



CA-MXS6MDR	MAIN SYSTEM
SP-MXS6MD	SPEAKER SYSTEM

Area Suffix	
B U.K.
E Continental Europe
EN Northern Europe

Contents

Safety precautions	1-2	Maintenance of laser pickup (MD)	1-38
Preventing static electricity	1-4	Replacement of laser pickup (MD)	1-38
Important for laser products	1-5	Flow of functional operation	
Disassembly method	1-6	until TOC read (CD section)	1-39
Adjustment method	1-31	Maintenance of laser pickup (CD)	1-40
Flow of functional operation		Replacement of laser pickup (CD)	1-40
until TOC read (MD section)	1-37	Description of major ICs	1-41

Safety Precautions

1. This design of this product contains special hardware and many circuits and components specially for safety purposes. For continued protection, no changes should be made to the original design unless authorized in writing by the manufacturer. Replacement parts must be identical to those used in the original circuits. Services should be performed by qualified personnel only.
2. Alterations of the design or circuitry of the product should not be made. Any design alterations of the product should not be made. Any design alterations or additions will void the manufacturer's warranty and will further relieve the manufacture of responsibility for personal injury or property damage resulting therefrom.
3. Many electrical and mechanical parts in the products have special safety-related characteristics. These characteristics are often not evident from visual inspection nor can the protection afforded by them necessarily be obtained by using replacement components rated for higher voltage, wattage, etc. Replacement parts which have these special safety characteristics are identified in the Parts List of Service Manual. Electrical components having such features are identified by shading on the schematics and by (\triangle) on the Parts List in the Service Manual. The use of a substitute replacement which does not have the same safety characteristics as the recommended replacement parts shown in the Parts List of Service Manual may create shock, fire, or other hazards.
4. The leads in the products are routed and dressed with ties, clamps, tubings, barriers and the like to be separated from live parts, high temperature parts, moving parts and/or sharp edges for the prevention of electric shock and fire hazard. When service is required, the original lead routing and dress should be observed, and it should be confirmed that they have been returned to normal, after re-assembling.
5. Leakage current check (Electrical shock hazard testing)
After re-assembling the product, always perform an isolation check on the exposed metal parts of the product (antenna terminals, knobs, metal cabinet, screw heads, headphone jack, control shafts, etc.) to be sure the product is safe to operate without danger of electrical shock. Do not use a line isolation transformer during this check.

- Plug the AC line cord directly into the AC outlet. Using a "Leakage Current Tester", measure the leakage current from each exposed metal parts of the cabinet, particularly any exposed metal part having a return path to the chassis, to a known good earth ground. Any leakage current must not exceed 0.5mA AC (r.m.s.)

- Alternate check method

Plug the AC line cord directly into the AC outlet. Use an AC voltmeter having, 1,000 ohms per volt or more sensitivity in the following manner. Connect a 1,500 Ω 10W resistor paralleled by a 0.15 μ F AC-type capacitor between an exposed metal part and a known good earth ground.

Measure the AC voltage across the resistor with the AC voltmeter.

Move the resistor connection to each exposed metal part, particularly any exposed metal part having a return path to the chassis, and measure the AC voltage across the resistor. Now, reverse the plug in the AC outlet and repeat each measurement. voltage measured Any must not exceed 0.75 V AC (r.m.s.). This corresponds to 0.5 mA AC (r.m.s.).

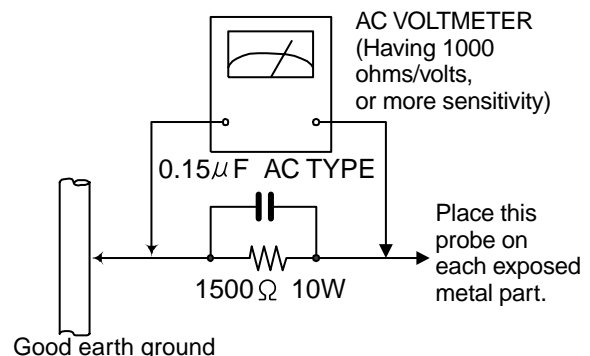

Warning

1. This equipment has been designed and manufactured to meet international safety standards.
2. It is the legal responsibility of the repairer to ensure that these safety standards are maintained.
3. Repairs must be made in accordance with the relevant safety standards.
4. It is essential that safety critical components are replaced by approved parts.
5. If mains voltage selector is provided, check setting for local voltage.

CAUTION Burrs formed during molding may be left over on some parts of the chassis. Therefore, pay attention to such burrs in the case of performing repair of this system.

Safety precautions (U.K only)

1. This design of this product contains special hardware and many circuits and components specially for safety purposes. For continued protection, no changes should be made to the original design unless authorized in writing by the manufacturer. Replacement parts must be identical to those used in the original circuits.
2. Any unauthorised design alterations or additions will void the manufacturer's guarantee ; furthermore the manufacturer cannot accept responsibility for personal injury or property damage resulting therefrom.
3. Essential safety critical components are identified by () on the Parts List and by shading on the schematics, and must never be replaced by parts other than those listed in the manual. Please note however that many electrical and mechanical parts in the product have special safety related characteristics. These characteristics are often not evident from visual inspection. Parts other than specified by the manufacturer may not have the same safety characteristics as the recommended replacement parts shown in the Parts List of the Service Manual and may create shock, fire, or other hazards.
4. The leads in the products are routed and dressed with ties, clamps, tubings, barriers and the like to be separated from live parts, high temperature parts, moving parts and/or sharp edges for the prevention of electric shock and fire hazard. When service is required, the original lead routing and dress should be observed, and it should be confirmed that they have been returned to normal, after re-assembling.

Warning

1. Service should be performed by qualified personnel only.
2. This equipment has been designed and manufactured to meet international safety standards.
3. It is the legal responsibility of the repairer to ensure that these safety standards are maintained.
4. Repairs must be made in accordance with the relevant safety standards.
5. It is essential that safety critical components are replaced by approved parts.
6. If mains voltage selector is provided, check setting for local voltage.

 **CAUTION** Burrs formed during molding may be left over on some parts of the chassis. Therefore, pay attention to such burrs in the case of performing repair of this system.

Preventing static electricity

Electrostatic discharge (ESD), which occurs when static electricity stored in the body, fabric, etc. is discharged, can destroy the laser diode in the traverse unit (optical pickup). Take care to prevent this when performing repairs.

1.1. Grounding to prevent damage by static electricity

Static electricity in the work area can destroy the optical pickup (laser diode) in devices such as CD/MD players. Be careful to use proper grounding in the area where repairs are being performed.

1.1.1. Ground the workbench

1. Ground the workbench by laying conductive material (such as a conductive sheet) or an iron plate over it before placing the traverse unit (optical pickup) on it.

1.1.2. Ground yourself

1. Use an anti-static wrist strap to release any static electricity built up in your body.

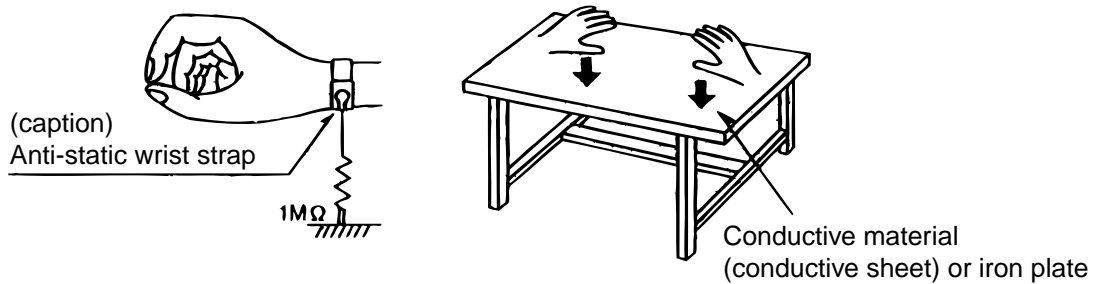

1.1.3. Handling the optical pickup

1. In order to maintain quality during transport and before installation, both sides of the laser diode on the replacement optical pickup are shorted. After replacement, return the shorted parts to their original condition. (Refer to the text.)
2. Do not use a tester to check the condition of the laser diode in the optical pickup. The tester's internal power source can easily destroy the laser diode.

1.2. Handling the traverse unit (optical pickup)

1. Do not subject the traverse unit (optical pickup) to strong shocks, as it is a sensitive, complex unit.
2. Cut off the shorted part of the flexible cable using nippers, etc. after replacing the optical pickup. For specific details, refer to the replacement procedure in the text. Remove the anti-static pin when replacing the traverse unit. Be careful not to take too long a time when attaching it to the connector.
3. Handle the flexible cable carefully as it may break when subjected to strong force.
4. It is not possible to adjust the semi-fixed resistor that adjusts the laser power. Do not turn it

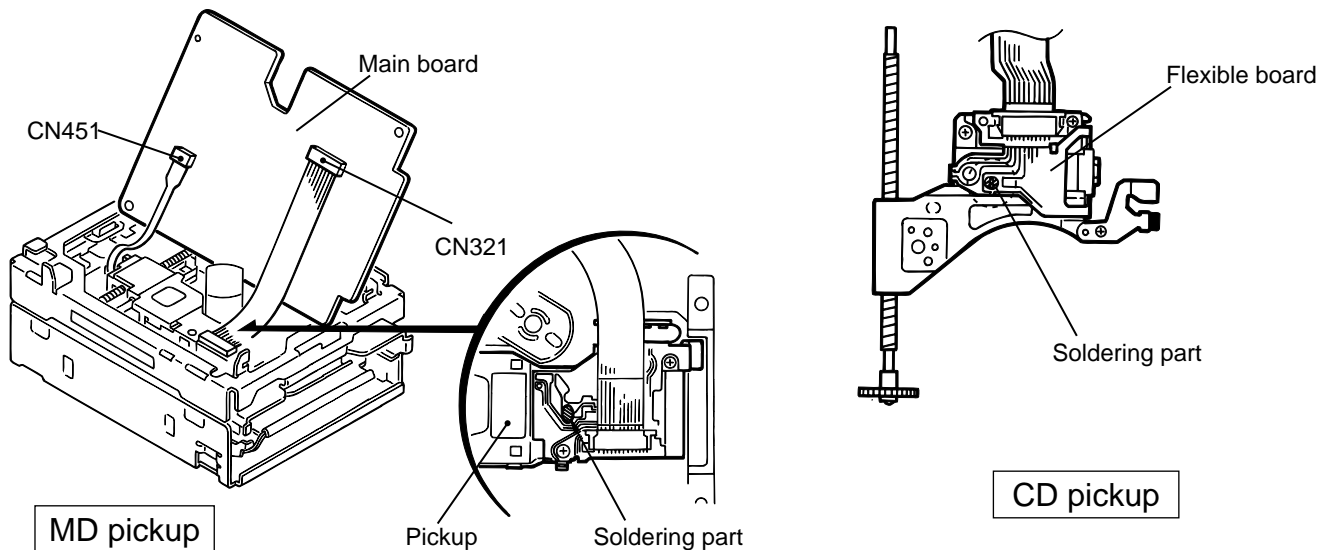

Important for laser products

1. CLASS 1 LASER PRODUCT

2.DANGER : Invisible laser radiation when open and interlock failed or defeated. Avoid direct exposure to beam.

3.CAUTION : There are no serviceable parts inside the Laser Unit. Do not disassemble the Laser Unit. Replace the complete Laser Unit if it malfunctions.

4.CAUTION : The compact disc player uses invisible laser radiation and is equipped with safety switches which prevent emission of radiation when the drawer is open and the safety interlocks have failed or are defeated. It is dangerous to defeat the safety switches.

5.CAUTION : If safety switches malfunction, the laser is able to function.

6.CAUTION : Use of controls, adjustments or performance of procedures other than those specified herein may result in hazardous radiation exposure.

⚠ CAUTION Please use enough caution not to see the beam directly or touch it in case of an adjustment or operation check.

VARNING : Osynlig laserstrålning är denna del är öppnad och spårren är urkopplad. Betrakta ej strålen.

VARO : Avattaessa ja suojalukitus ohitettaessa olet alttiina näkymättömälle lasersäteilylle. Älä katso säteeseen.

ADVARSEL : Usynlig laserstrålning ved åbning , når sikkerhedsafbrydere er ude af funktion. Undgå udsættelse for stråling.

ADVARSEL : Usynlig laserstrålning ved åpning, når sikkerhetsbryteren er avslott. unngå utsettelse for stråling.

REPRODUCTION AND POSITION OF LABEL

WARNING LABEL

**CLASS 1
LASER PRODUCT**



DANGER : Invisible laser radiation when open and interlock or defeated. AVOID DIRECT EXPOSURE TO BEAM (e)	VARO : Avattaessa ja suojalukitus ohitettaessa olet alttiina näkymättömälle lasersäteilylle. Älä katso säteeseen. (d)
VARNING : Osynlig laserstrålning är denna del är öppnad och spårren är urkopplad. Betrakta ej strålen. (s)	ADVARSEL : Usynlig laserstrålning ved åbning , når sikkerhedsafbrydere er ude af funktion. Undgå udsættelse for stråling. (f)

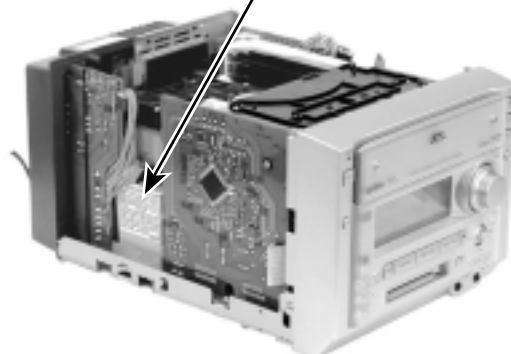

Disassembly method

<Main body>

■ Removing the top cover

(See Fig. 1 and 2)

1. Remove the four screws **A** on the back of the body.
2. Remove the two screws **B** on both sides of the body.
3. Lift up the rear part of the top cover while pulling both sides, then remove the top cover.

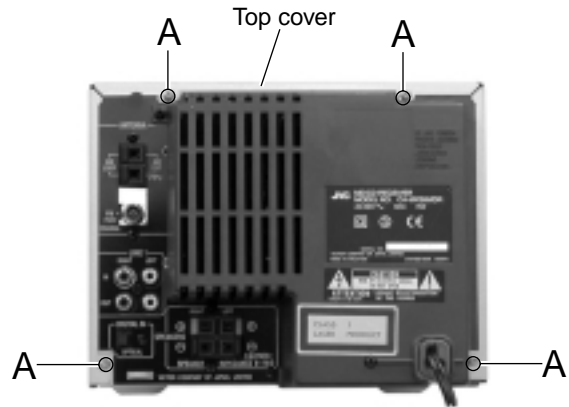

Fig.1

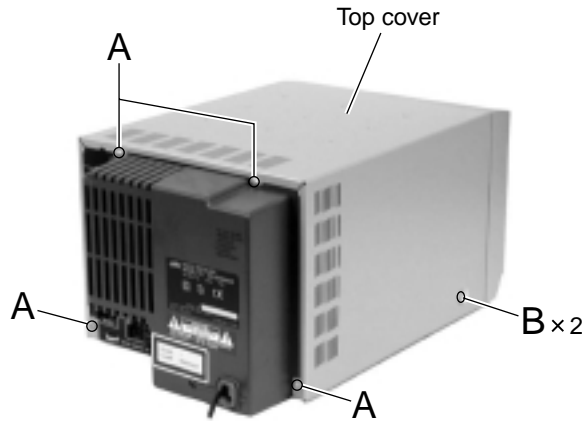

Fig.2

■ Removing the CD changer mechanism assembly (See Fig.3 to 5)

- Prior to performing the following procedure, remove the top cover.

1. Disconnect the card wire from connector CN661 on the input board.
2. Remove the four screws **C** on the upper side of the body.
3. Remove the screw **D** on the left side of the body.
4. Release the wires from the clamp on the right side of the CD changer mechanism assembly. Lift up the rear part of the CD changer mechanism assembly and pull out it from the front assembly.

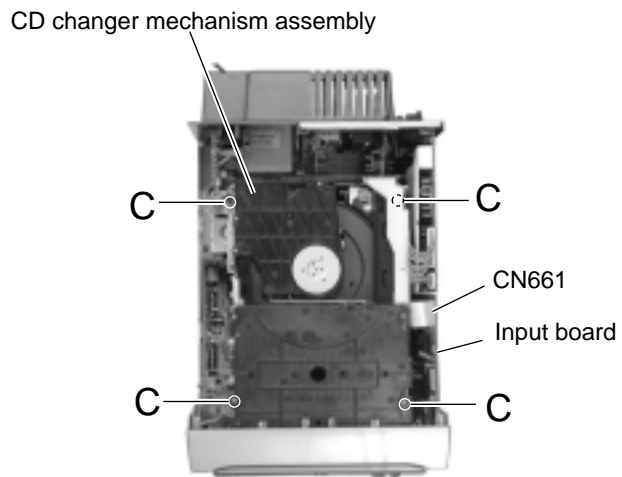

Fig.3

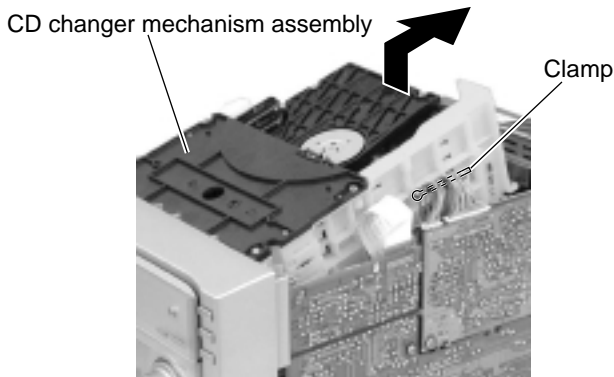

Fig.5

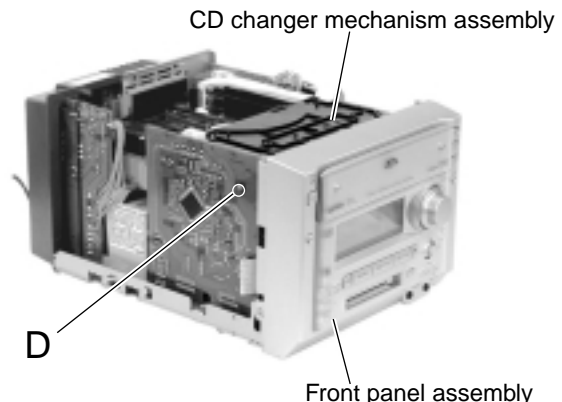

Fig.4

■ Removing the front panel assembly (See Fig.6 to 8)

- Prior to performing the following procedure, remove the top cover.
1. Disconnect the wire from connector CN603 on the input board and the card wire from CN801 on the microcomputer board.
 2. Remove the two screws **E** on the bottom of the body.
 3. Release the joint **a** on the bottom and the two joints **b** and **c** on the lower sides of the body using a screwdriver. Detach the front panel assembly toward the front.

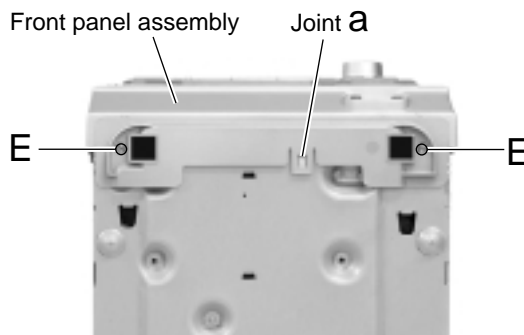

Fig.6

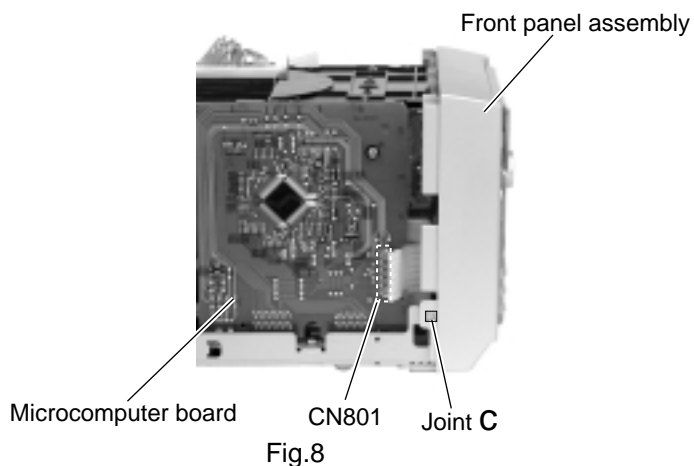

Fig.8

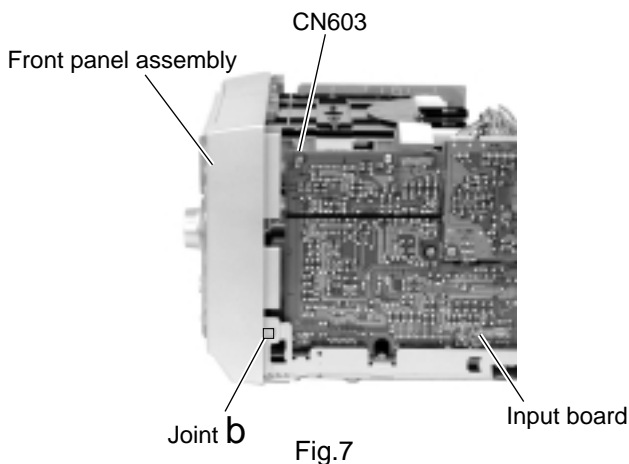

Fig.7

■ Removing the display board (See Fig.9)

- Prior to performing the following procedure, remove the top cover and the front panel assembly.
1. Remove the nine screws **F** attaching the display board to the front panel assembly.
 2. Disconnect connector CN791 on the display board from the control board on the front panel assembly.

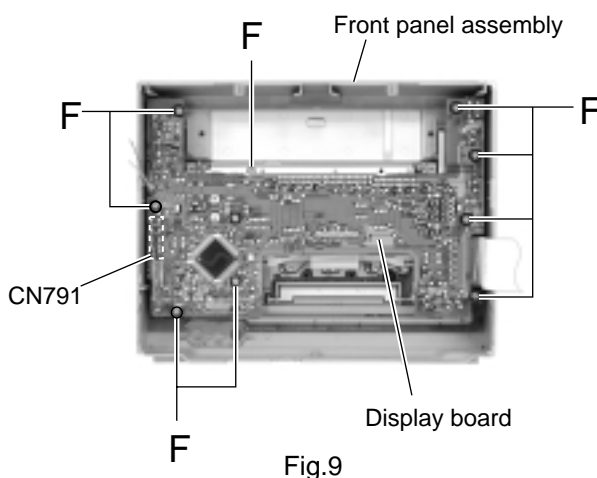

Fig.9

■ Removing the control board / the key board (See Fig.10)

- Prior to performing the following procedure, remove the top cover, the front panel assembly and the display board.
1. Remove the five screws **G** and the four screws **H** attaching the control board and the key board.

REFERANCE: When removing the control board and the key board respectively, unsolder each board.

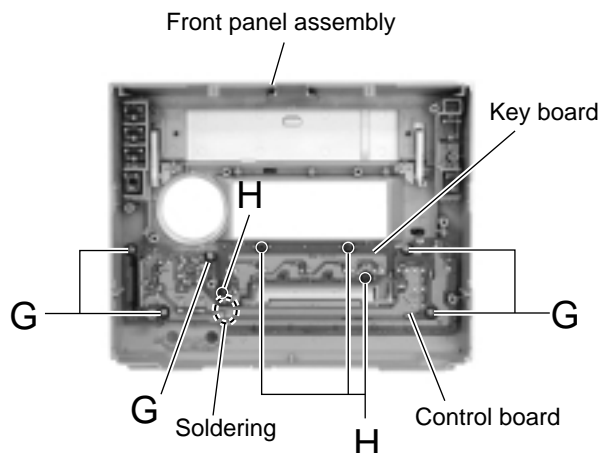
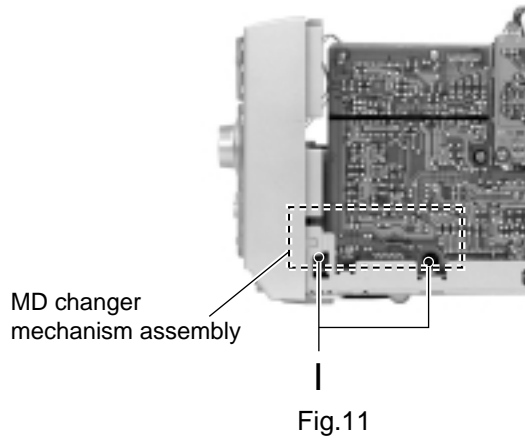

Fig.10

■ Removing the MD changer mechanism (See Fig.11 to 13)

- Prior to performing the following procedure, remove the top cover and the CD changer mechanism assembly.

1. Disconnect the card wire from connectors CN511 on the main board.
2. Remove the four screws **I** on both sides of the body.
3. Pull out the MD changer mechanism assembly from behind upward while releasing the four joints **d** using a screwdriver.



■ Removing the microcomputer board (See Fig.14)

- Prior to performing the following procedure, remove the top cover.

1. Disconnect the card wire from connector CN801 on the microcomputer board.
2. Remove the screw **D** attaching the microcomputer board.
3. Disconnect the lower connector CN391, CN392 and CN393 from the main board by pulling them.

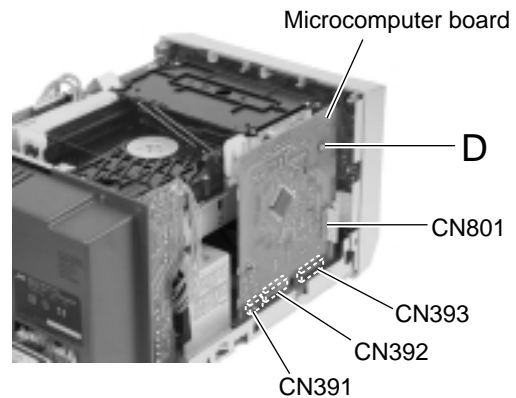
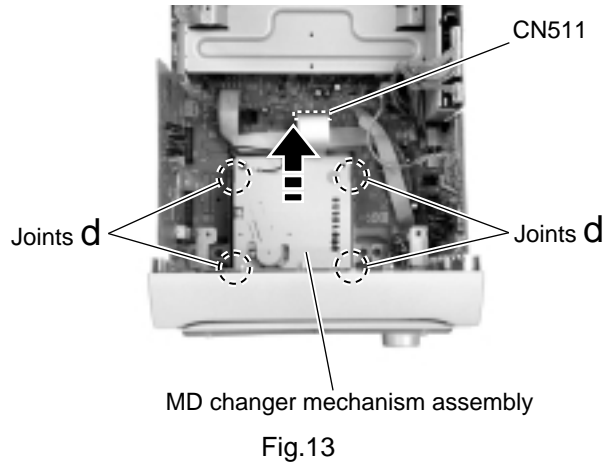
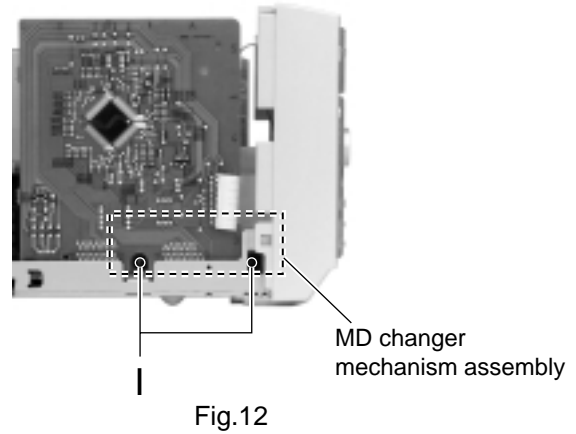

■ Removing the tuner board (See Fig.15 and 16)

- Prior to performing the following procedure, remove the top cover.
1. Disconnect the wire from connector CN111 and CN112 on the tuner board.
 2. Remove the screw **J** on the side of the body.
 3. Remove the two screws **K** on the back of the rear panel.

REFERANCE: To facilitate the procedure, remove the rear panel in advance.

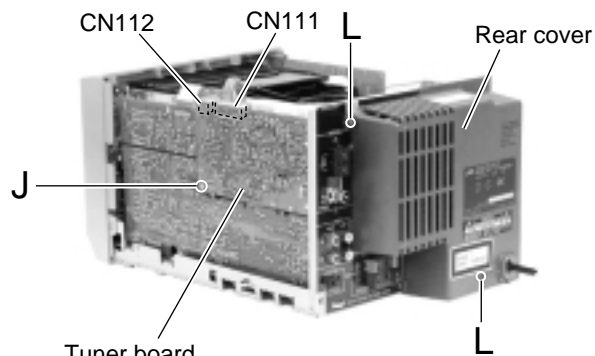

Fig.15

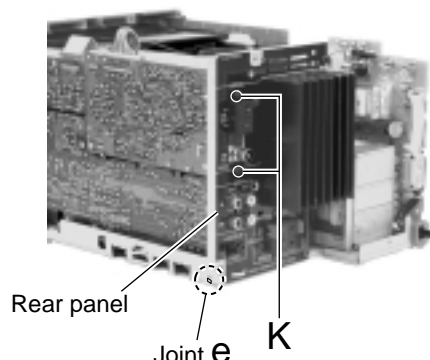

Fig.16

■ Remove the rear cover / the rear panel (See Fig.15 and 17)

- Prior to performing the procedure, remove the top cover.
1. Remove the two screws **L** attaching the rear cover to the body.
 2. Remove the two screws **K, M, N, O**, and the screw **P** and **Q** respectively.
 3. Release the joint **e** on the lower left side of the rear panel.

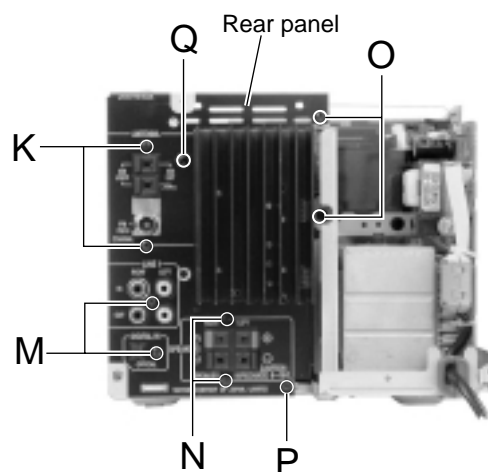

Fig.17

■ Removing the Input board (See Fig.18)

- Prior to performing the procedure, remove the top cover, the rear cover, the rear panel and the tuner board.
1. Disconnect the card wire from connector CN661 and the wire from CN603 on the input board.
 2. Remove the two screws **R** attaching the bracket and remove the bracket in the direction of the arrow.
 3. Disconnect the lower connector CN602, CN913 and CN922 from the main board. Disconnect the wire from CN691 on the input board.

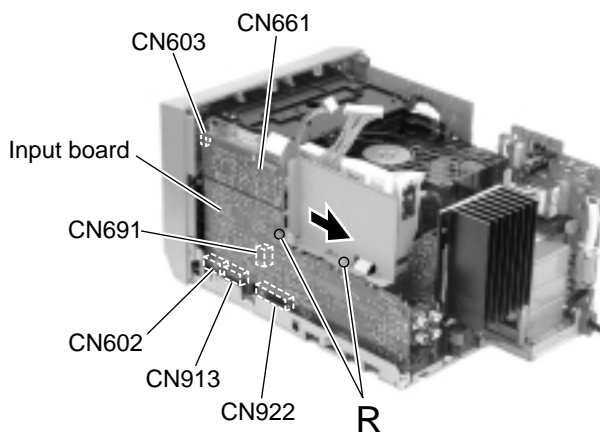

Fig.18

■ Removing the heat sink assembly (See Fig.19 and 20)

- Prior to performing the procedure, remove the top cover, the CD changer mechanism assembly, the rear cover, the rear panel, the tuner board and the input board.

1. Remove the four screws **S** attaching the bracket.
2. Disconnect connector CN924 and CN394 from the main board.

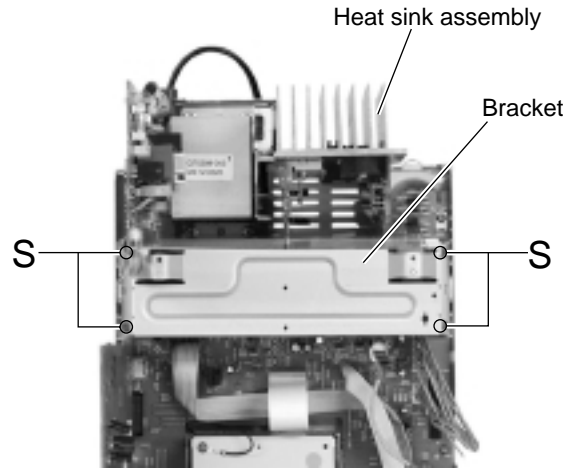

Fig.19

■ Removing the regulator board / the amplifier board (See Fig.21)

- Prior to performing the procedure, remove the top cover, the CD changer mechanism assembly, the rear cover, the rear panel, the tuner board, the input board and the heat sink assembly.

1. Remove the two screws **T** or **U** attaching the regulator board and the amplifier board to the heat sink.

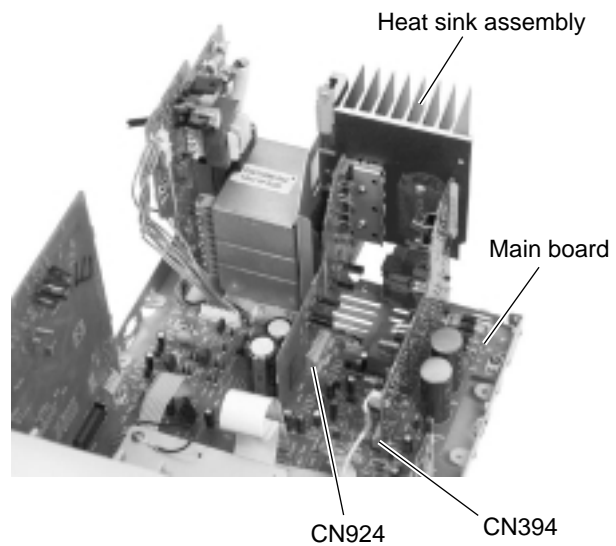

Fig.20

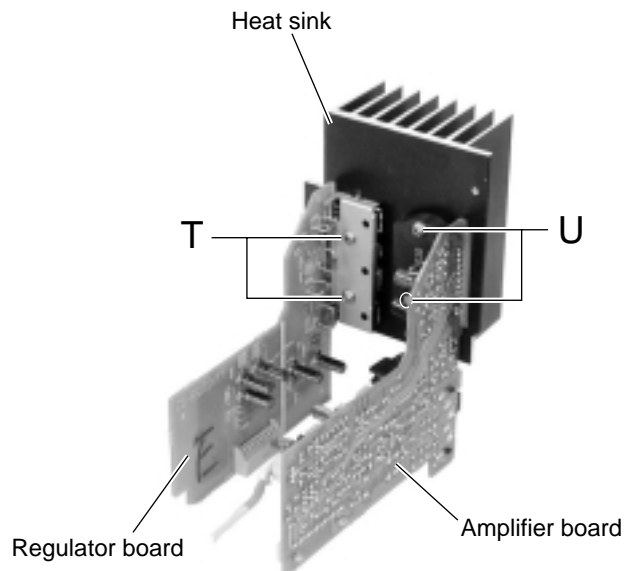

Fig.21

■ Removing the Main board (See Fig.22)

- Prior to performing the procedure, remove the top cover, the CD changer mechanism assembly, the rear cover, the rear panel, the tuner board, the input board and the heat sink assembly.

1. Disconnect the wire from connector CN911 on the main board and CN991 on the power transformer assembly.
2. Disconnect the card wire from connector CN511 on the main board.
3. Remove the four screws **V** attaching the main board.
4. If necessary, unsolder the wire on the headphone board.

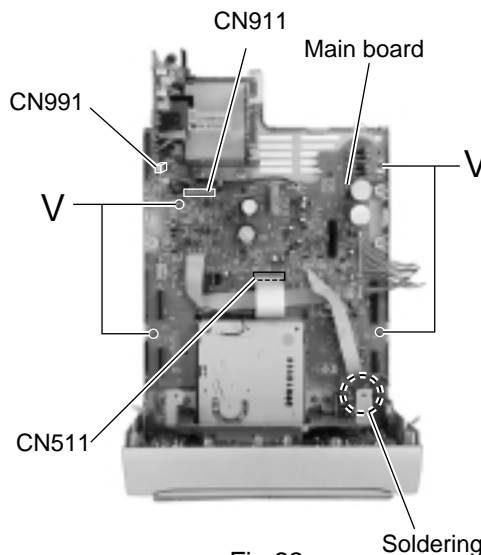

Fig.22

■ Removing the power transformer assembly (See Fig.23 and 24)

- Prior to performing the following procedure, remove the top cover and the rear cover.

1. Remove the four screws **W** attaching the power transformer assembly.
2. Pull out the power cord stopper from the body upward. Turn the power transformer assembly while lifting it as shown in the figure.
3. Disconnect the wire from connector CN911 on the main board and CN991 on the power transformer board. Remove the power transformer assembly from the body.

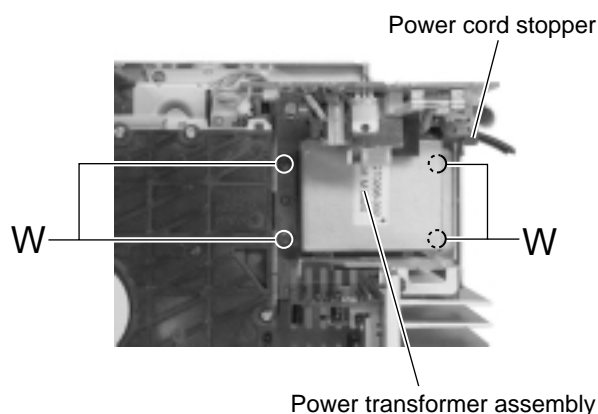

Fig.23

■ Removing the headphone board (See Fig.25)

- Prior to performing the procedure, remove the top cover, the CD changer mechanism assembly, the front panel assembly, the rear cover, the rear panel, the tuner board and the input board.

1. Remove the screw **X** attaching the headphone board.

If necessary, unsolder the wire on the headphone board.

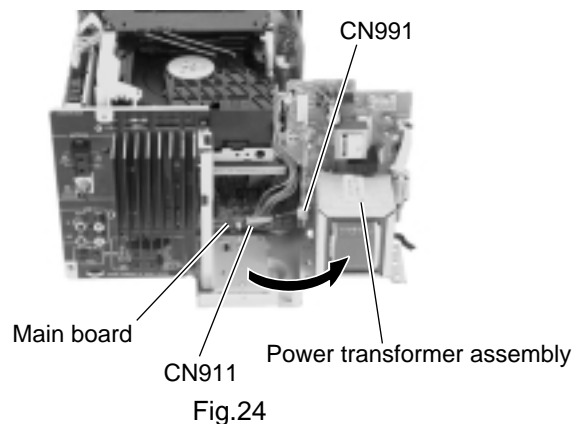

Fig.24

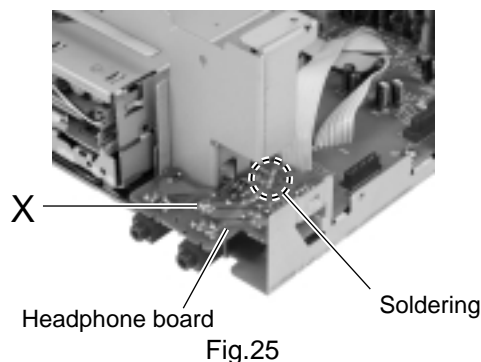

Fig.25

<MD section>

■Removing the main board
 (See Fig.1 and 2)

1. Turn over the body and disconnect the card wire from connector CN408 and the flexible wire from CN407 on the main board.
2. Remove the two screws A attaching the main board. Slide the main board in the direction of the arrow to release the two joints a with the single flame.
3. Solder part b on the pickup in the body. Disconnect the flexible harness from connector CN321 and CN451 on the underside of the main board. Then remove the main board.

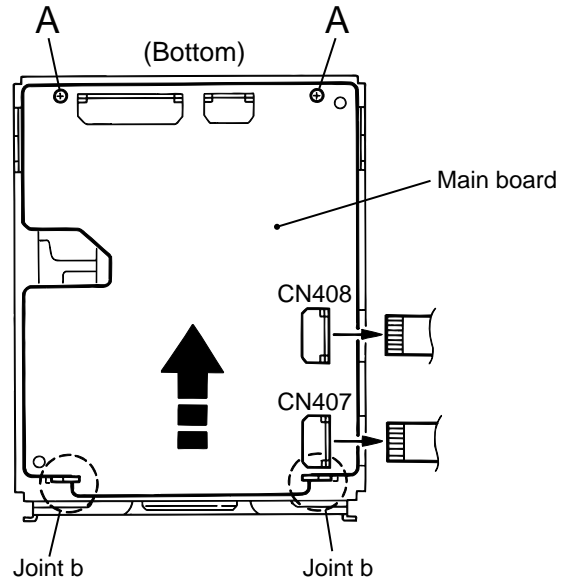

Fig.1

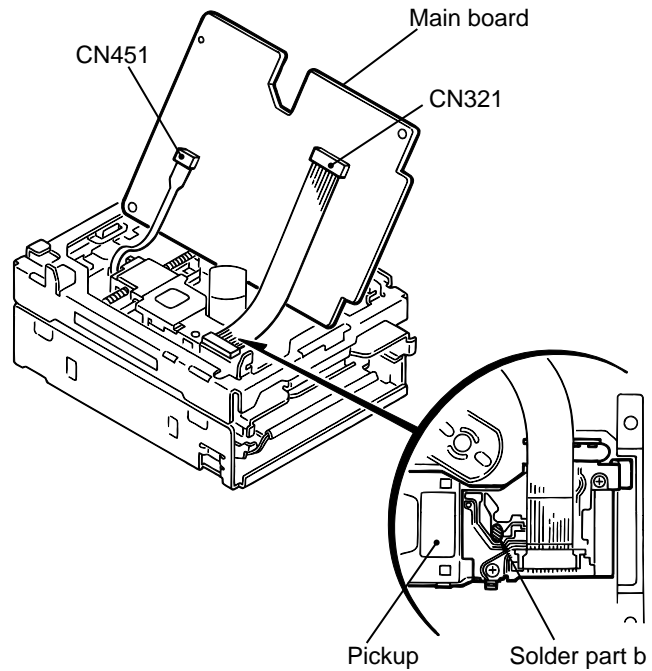

Fig.2

■Removing the mechanism cover
 (See Fig.3)

1. Remove the four screws B on both sides of the body.
2. Move the mechanism cover toward the front to disengage the front hook of the mechanism cover from the internal loading assembly (Joint c). Then remove the mechanism cover upward.

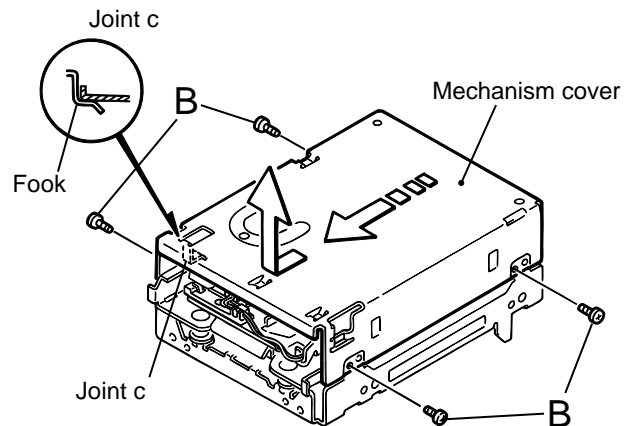
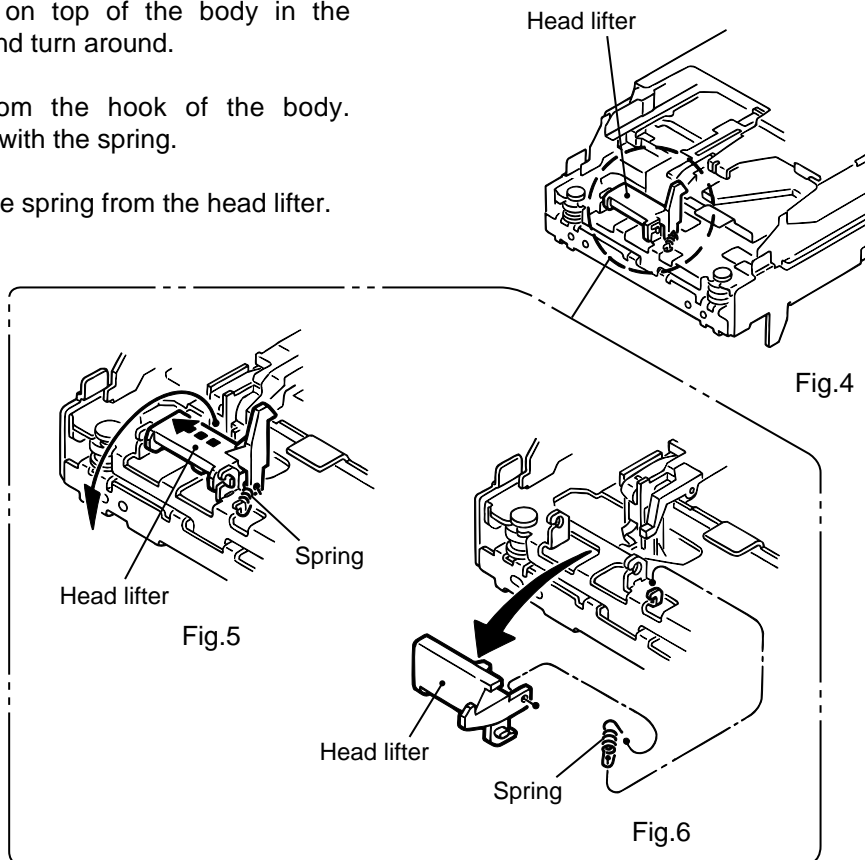

Fig.3

■ **Removing the head lifter (See Fig.4 to 6)**

1. Move the head lifter on top of the body in the direction of the arrow and turn around.
2. Detach the spring from the hook of the body. Remove the head lifter with the spring.
3. If necessary, remove the spring from the head lifter.



■ **Removing the head assembly (See Fig.7)**

1. Remove the screw C on the upper side of the body. Remove the head assembly while pulling the flexible harness from the body.

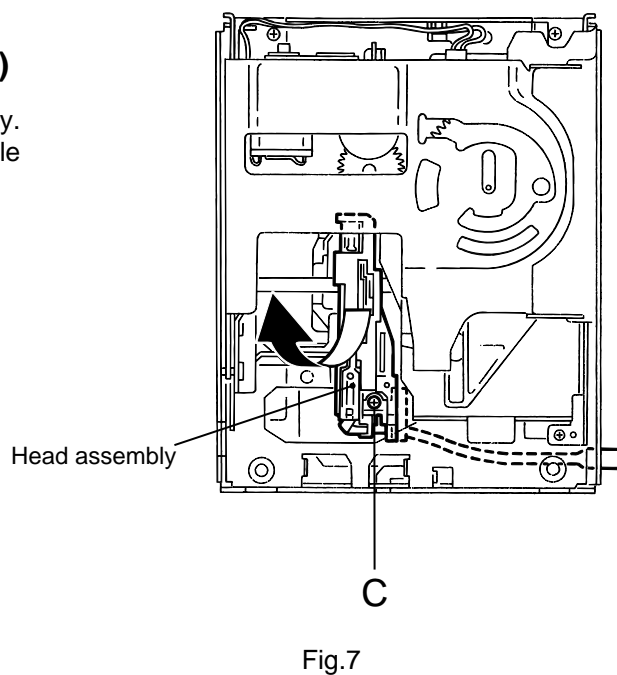

■ Removing the Loading assembly (See Fig.8 and 9)

Ref: The loading assembly, the traverse mechanism assembly and the single flame will be removable after removing the loading assembly from the body.

• Prior to performing the following procedure, remove the main board, the mechanism cover, the head lifter and the head assembly.

1. Remove the three screws D on the upper side of the body.
2. Move the loading assembly forward to disengage it from the traverse mechanism assembly (Joint d). Then remove it upward.
3. Remove the traverse mechanism assembly from the single flame.

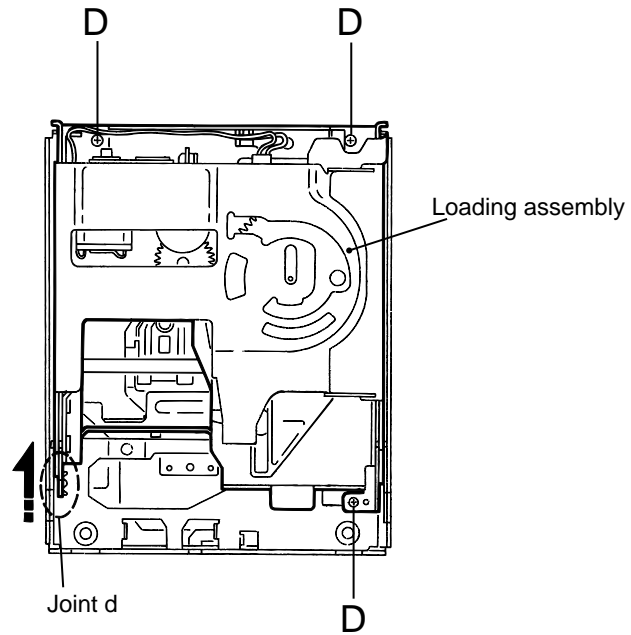

Fig.8

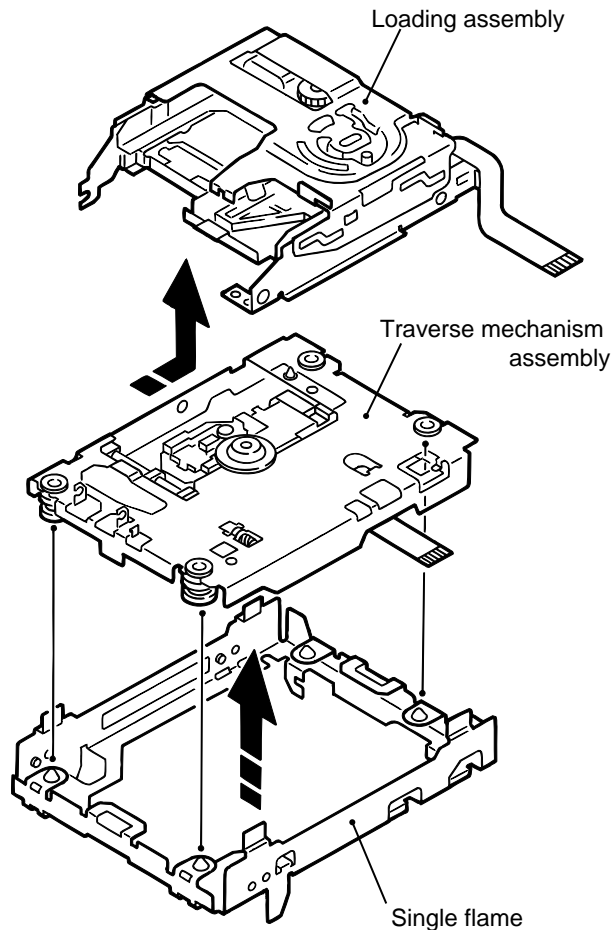

Fig.9

<Loading assembly>

■Removing the slide base (L) / (R)
(See Fig.10)

1. Remove the two screws E on the upper side of the loading assembly.
2. Remove the slide base (L) outward. (Release it from the joint bosses E.)
3. Remove the slide base (R) outward.

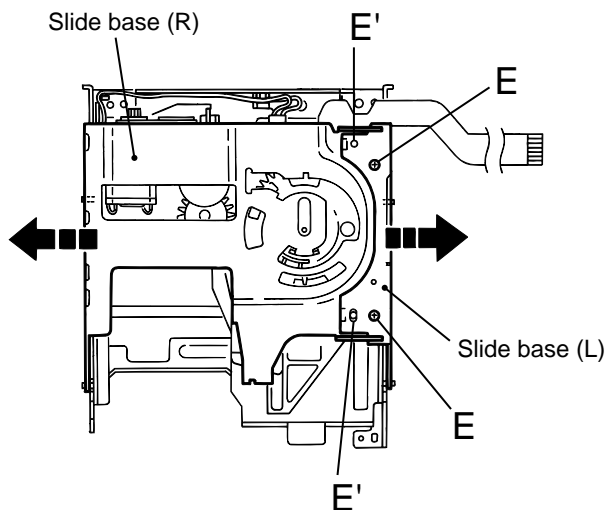

Fig.10

■Removing the loading mechanism assembly (See Fig.11)

1. Detach the loading mechanism assembly upward to release the four pins on both sides from the loading motor, paying attention to the part e of the loading mechanism base.

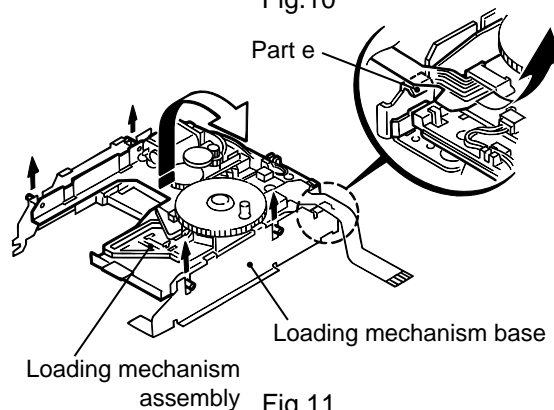

Fig.11

— Loading mechanism assembly —

■Removing the loading motor
(See Fig.12 and 13)

1. Disconnect the harnesses from the wire holder and from connector CN612 on the cam switch board.
2. Remove the screw F attaching the loading motor and release the joint f.
3. Remove the belt from the loading motor assembly.
4. Remove the two screws G attaching the loading motor.

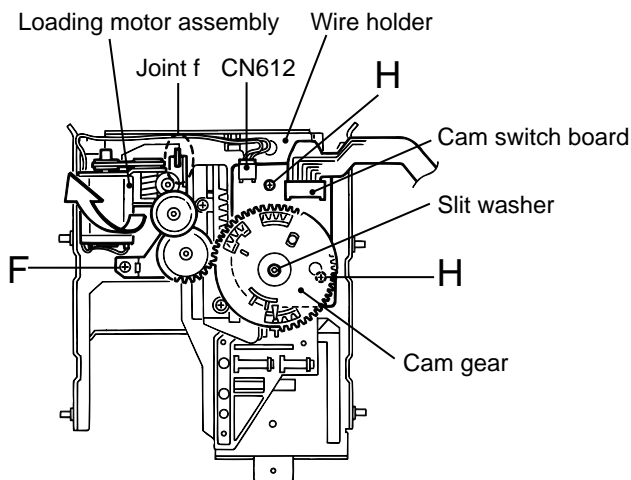

Fig.12

■Removing the cam gear and the cam switch board (See Fig.12)

1. Remove the slit washer attaching the cam gear and pull out the cam gear.
2. Disconnect the harness from the wire holder and from connector CN612 on the cam switch board.
3. Remove the two screws H and the clamp. Remove the cam switch board.

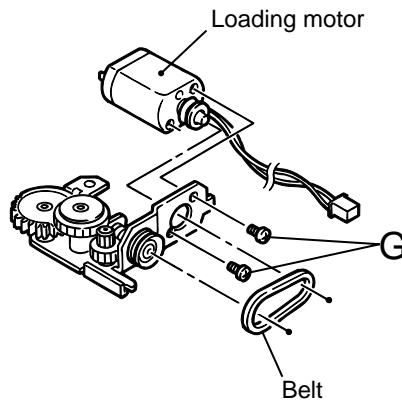

Fig.13

■ Removing the cartridge holder assembly (See Fig.14 and 15)

1. Remove the two screws I on the upper side of the loading assembly.

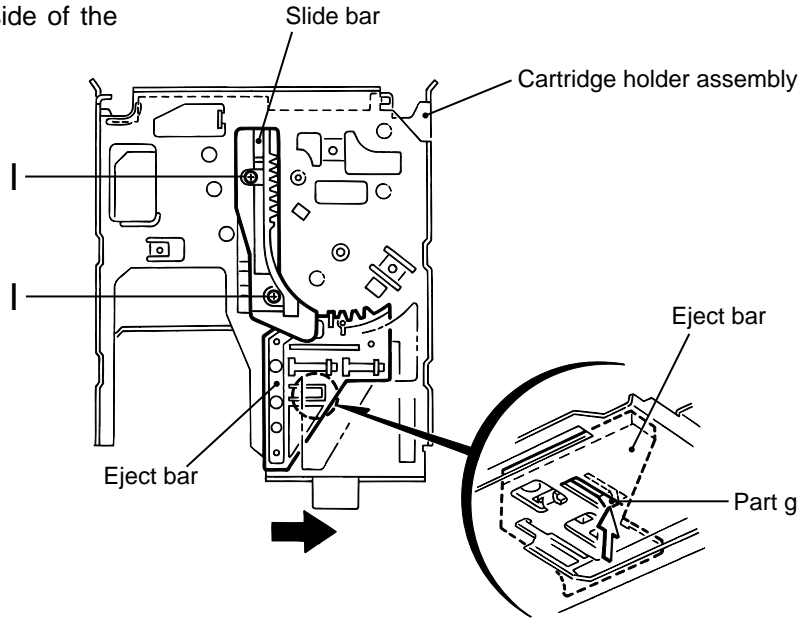

Fig.14

■ Removing the slide bar and the eject bar (See Fig.14 and 15)

- Prior to performing the following procedure, remove the cartridge holder assembly.

1. Remove the slide bar upward.
2. Move the eject bar outward until it stops as shown in Fig.14. Push the convex part g on the bottom of the body and remove the eject bar from the chassis.

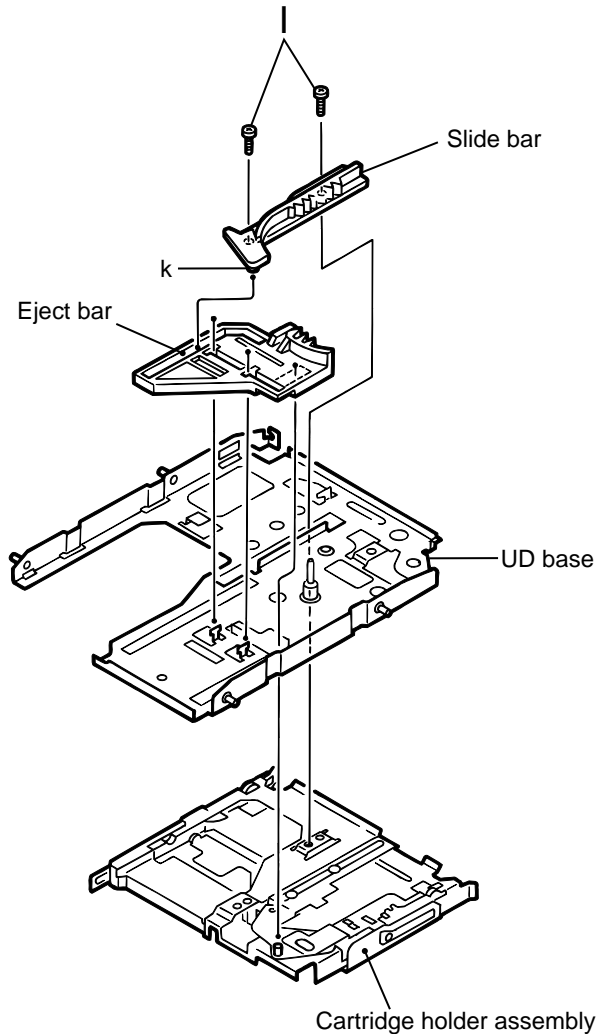

Fig.15

< Traverse mechanism assembly >

■ Removing the Insulators (See Fig.16)

1. Disengage the four insulators from the notches of the traverse mechanism chassis.

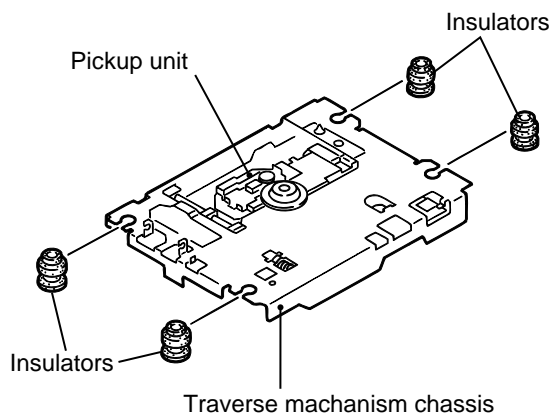

Fig.16

■ Removing the pickup unit (See Fig.17)

1. Turn over the traverse mechanism assembly and remove the screw J attaching the shaft holder (F).
2. Move the shaft inward and remove it from the shaft holder (R).
3. Detach the shaft side of the pickup unit upward and release the joint h with the pickup guide. Then remove the pickup unit with the shaft.

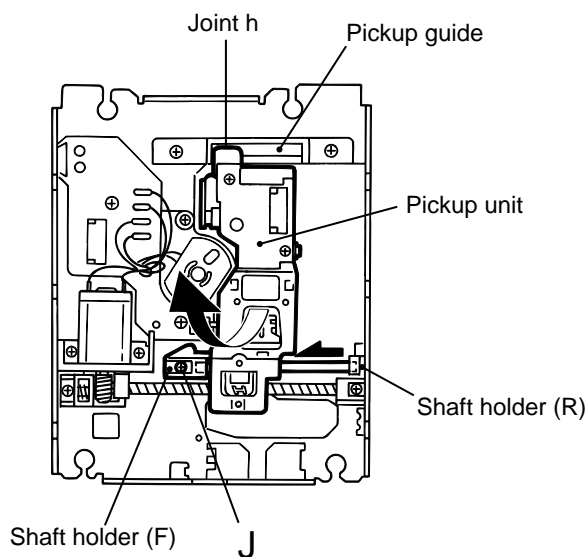

Fig.17

■ Removing the pickup (See Fig.18)

1. Draw out the shaft from the pickup.
2. Remove the two screws K attaching the rack spring.

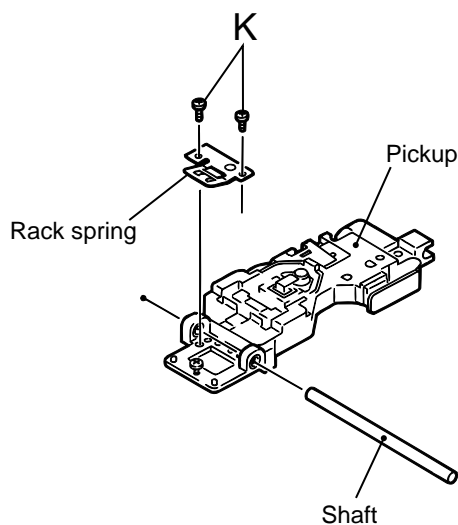

Fig.18

■Removing the feed motor assembly (See Fig.19-1, 19-2)

- It is not necessary to remove the pickup unit.
1. For the white and black harnesses extending from the feed motor assembly, unsolder the soldering i on the traverse mechanism board.
 2. Remove the two screws L attaching the feed motor assembly.
 3. Remove the two screws N attaching the feed motor bracket.

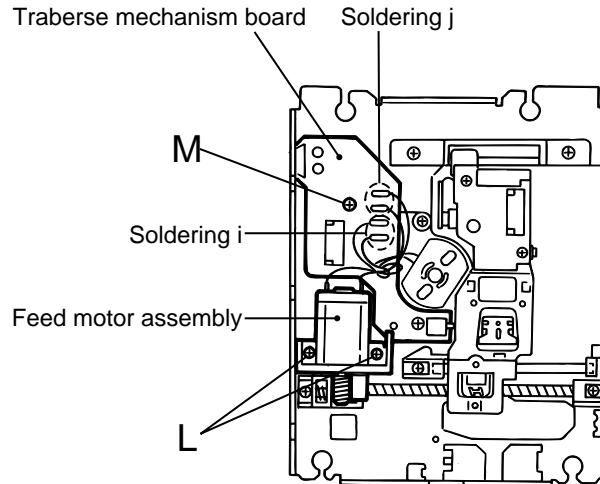

Fig.19-1

■Removing the traverse mechanism board (See Fig.19-1)

- Prior to performing procedure, remove the feed motor assembly.
1. For the red and black harnesses extending from the spindle motor, unsolder the soldering j on the traverse mechanism board.
 2. Remove the screw M attaching the traverse mechanism board.

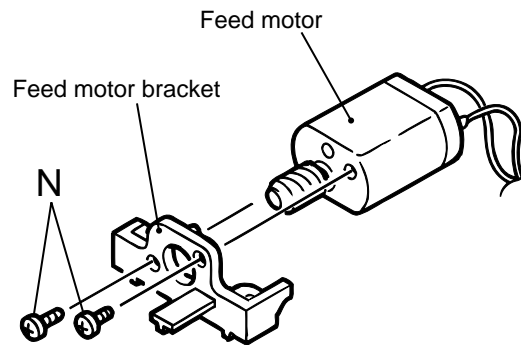

Fig.19-2

<Reattaching the loading assembly>

1. Reattach the eject bar to the UD base.
(Fig.15 and 20)
2. Reattach the slide bar to the loading mechanism chassis while fitting the boss marked k to the eject bar slot. (Fig.20)
3. Slide the slide bar and the eject bar in the direction of the arrow in Fig.20 and reattach the cartridge holder assembly using the two screws I.
(Fig.20 and 21)

ATTENTION: Make sure the pin of the eject lever marked I is fitted to the slot of the eject bar marked m at the bottom of the loading mechanism chassis after moving the eject lever and the loading slider of the cartridge holder assembly in the direction of the arrow.

(Refer to Fig.21)

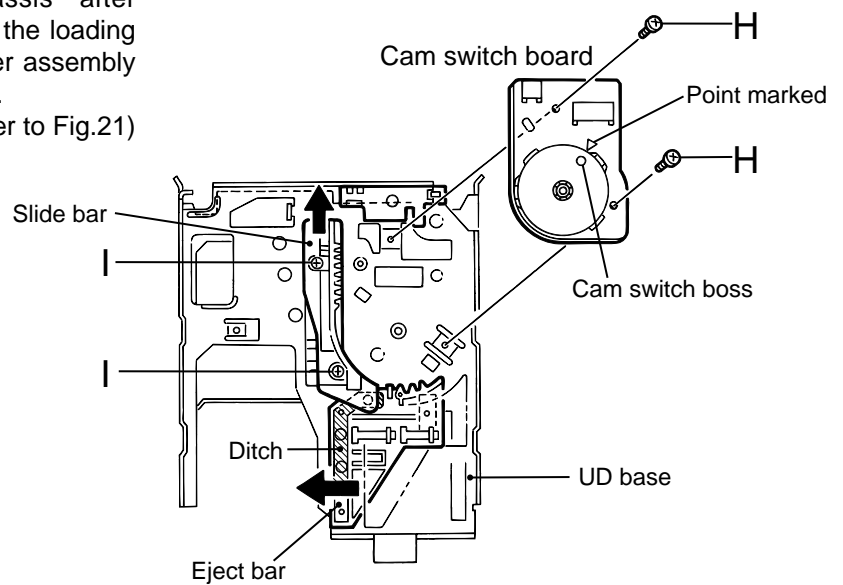

Fig.20

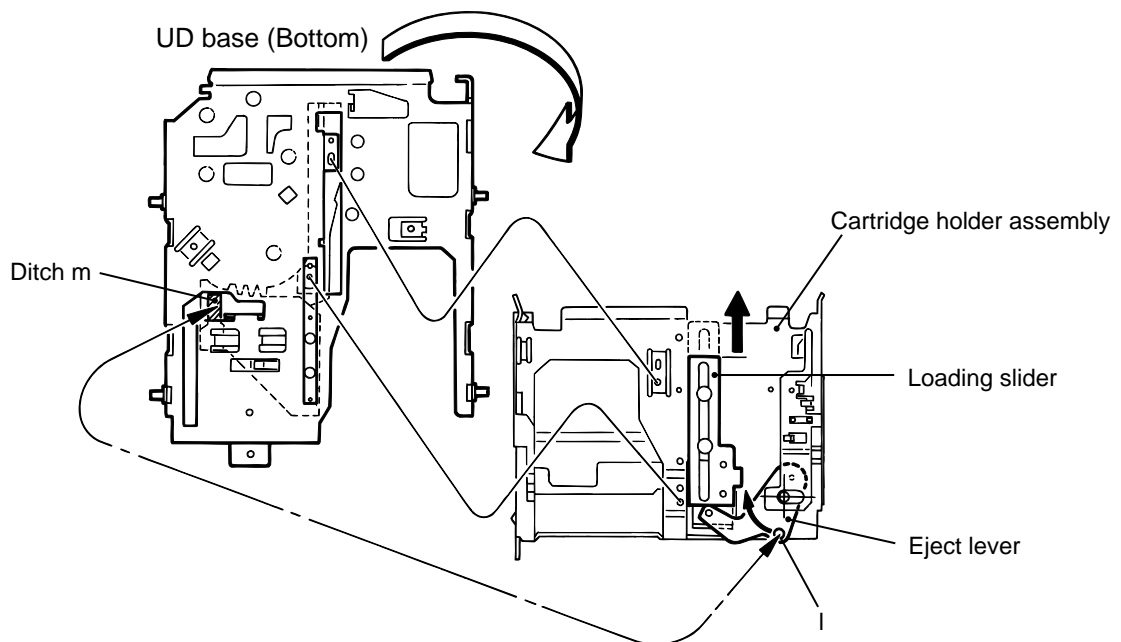

Fig.21

4. Reattach the wire holder to the UD base while engaging the UD base hook marked u to the wire holder slot marked t (At the same time, the boss on the reverse side of the wire holder is fitted to the UD base round hole).
5. Reattach the cam switch board using the two screws H. (Fig.22)
6. Turn the cam switch to bring the boss to the point marked Δ on the cam switch board. Reattach the cam gear using a slit washer while fitting the cam gear slot to the cam switch boss. (Fig.22)

ATTENTION: When reattaching the cam gear, the cam switch boss should be fitted to the cam gear slot, and the triangle mark of the cam gear should be aligned to the hole of the eject bar as shown in Fig.22.

7. Reattach the loading motor assembly, using the screw F. Connect the harness extending from the loading motor to connector CN612 on the switch board and fix it with the wire holder. (Fig.22)

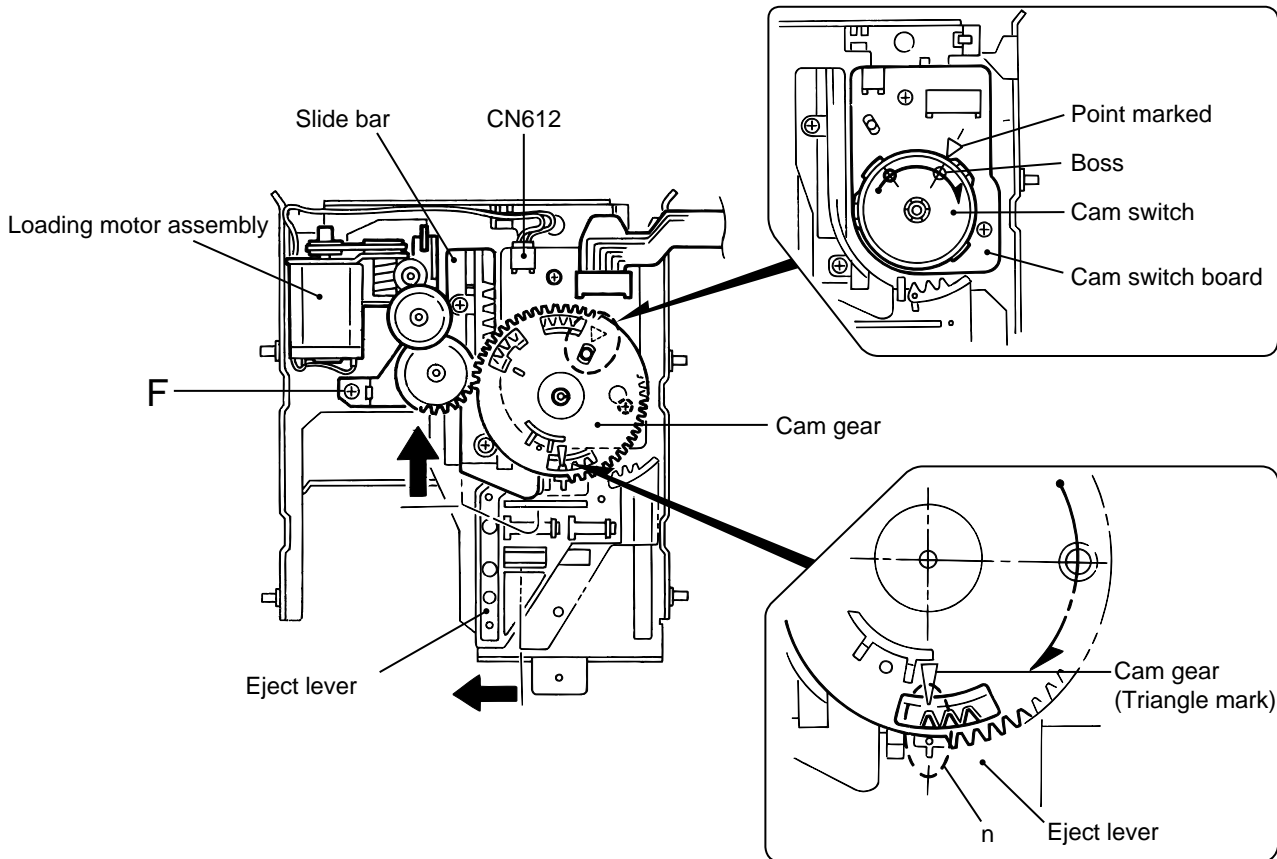

Fig.22

8. Reattach the UD base while engaging the four pins on both sides of the UD base to the notches of the loading mechanism base and placing the edge (marked e') of the cartridge holder assembly under the hook e of the loading mechanism base. (Fig.23)

9. Reattach the slide base (R) while fitting the two pins on another side of the UD base to the slots of the slide base (R). (Fig.24)

ATTENTION: Fit the part v of the slide base (R) to the part w on the inward side of the cam gear rib. (Fig.25)

10. Reattach the slide base (L) on the slide base (R) while fitting the two pins on another side of the UD base to the slots of the slide base (L) (Fig.25). Make sure the two slots of the slide base (L) are fitted to the two bosses marked E' and tighten the two screws E. (Fig.26)

Ref: To expedite the work, bring up the UD base slightly when fitting each pin to the appropriate notch.

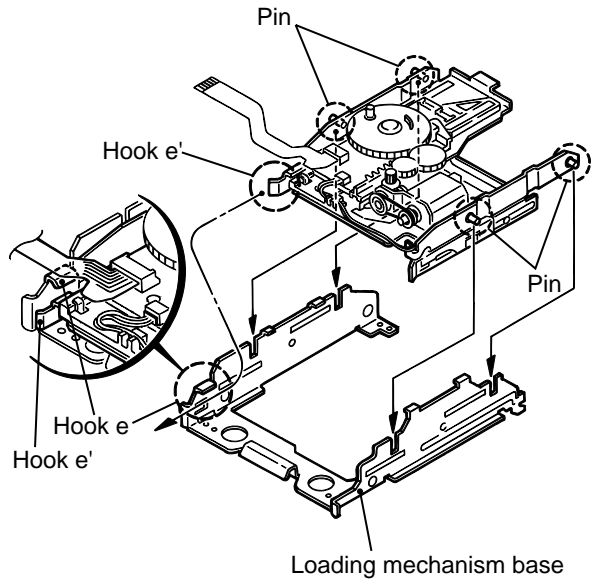

Fig.23

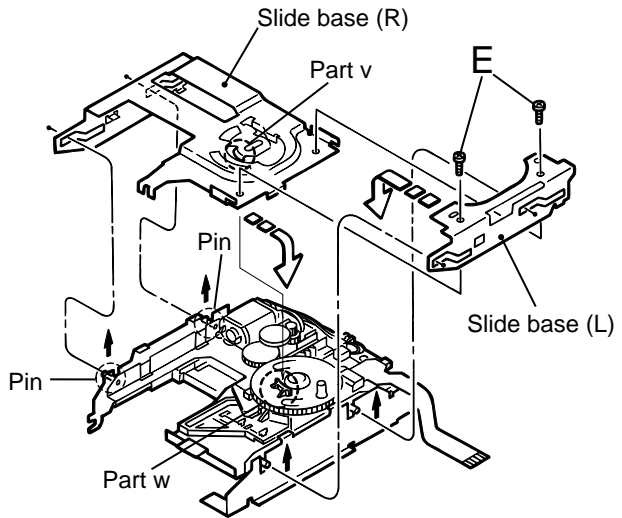

Fig.24

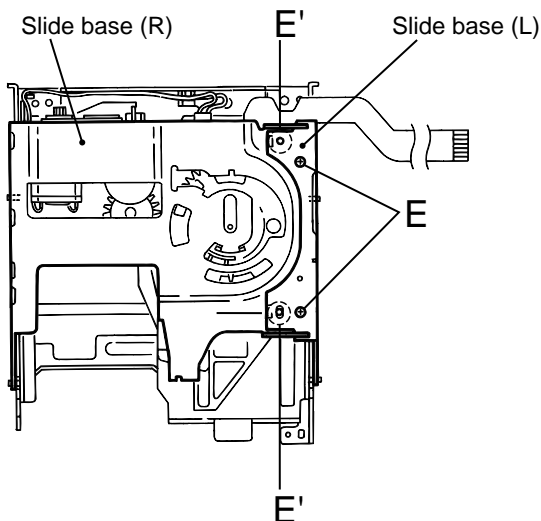

Fig.26

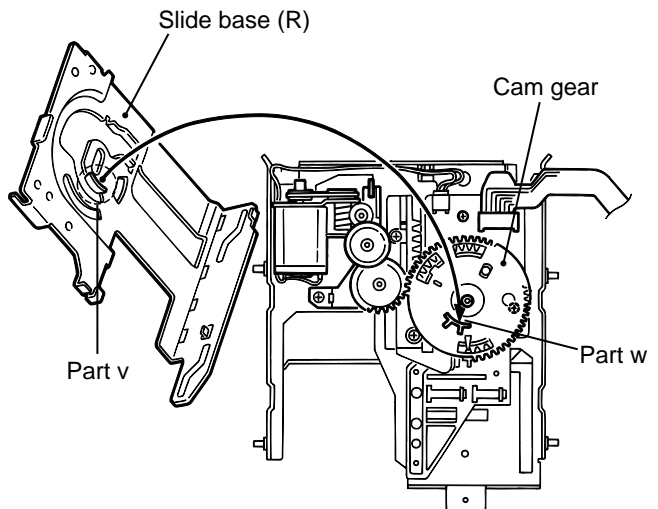

Fig.25

<CD mechanism section>

■ Removing the servo control board (See Fig.1 to 4)

ATTENTION: Make sure the sub chassis unit is locating at the lowest position. If not, perform the following procedure from 1 to 3.

1. Insert a screwdriver into the sub chassis slot on the back of the body and push the slider (R) toward the front.
2. From the top of the body, slide the hook and the slider (R) forward until they stop.
3. From the right side of the body, slide the slide cam (L) backward until it stops. The sub chassis unit will move to the lowest position.
4. From the bottom of the body, unsolder each soldered part a and b of the motors on the servo control board.
5. Remove the five screws A attaching the servo control board.
6. Disconnect connector CN610 on the servo control board from the tray select switch board to suspend the servo control board tentatively. Solder the part c of the flexible wire connected to connector CN601 on the underside of the servo control board.
7. Disconnect the flexible wire from connector CN601 and remove the servo control board from the body.

ATTENTION: In case of disconnecting the flexible wire without soldering, the CD pick up may be damaged.

ATTENTION: When reassembling, make sure the cam switch boss of the servo control board is fitted to the slot p of the control cam on the bottom of the body (Refer to Fig.3-1).

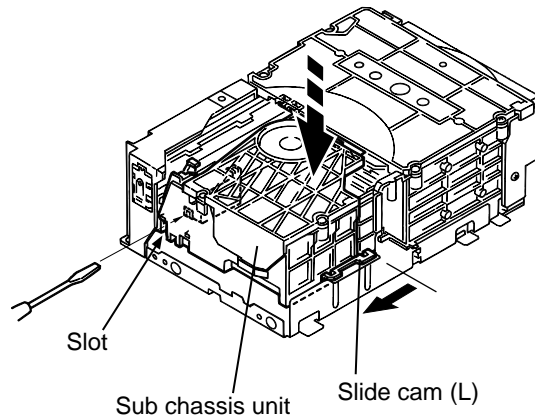

Fig.1

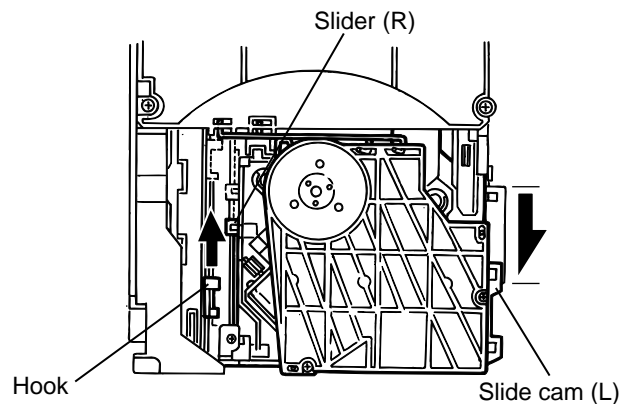

Fig.2

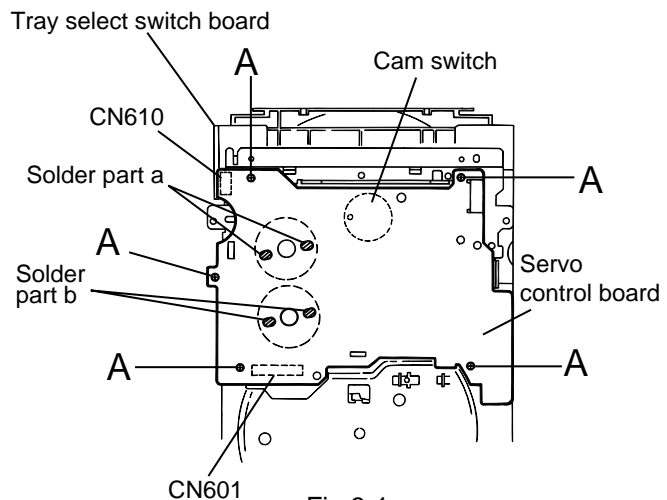

Fig.3-1

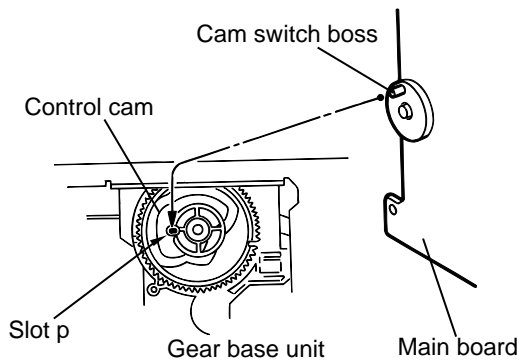

Fig.3-2

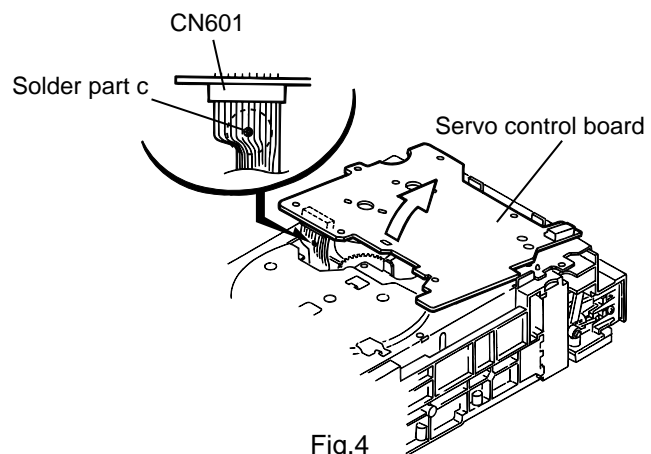

Fig.4

■ Removing the tray unit (See Fig.5 to 8)

※ The tray unit can be removed despite the position of the sub chassis unit, but the lowest position is recommended to expedite the work.

1. Remove the four screws B attaching the top cover on the top of the body.
2. Remove the top cover with the two rods attached to the top cover and the clamper base unit.
3. Pull the lock lever of the return spring on the right side of the body to eject the tray unit.
4. From the top of the body, release the tray from the joint hook marked d (Push the tray toward the front).
5. Release the stoppers on both sides in the direction of the arrow and pull out the tray unit from the body.

ATTENTION: Pull out the tray unit from the top tray 3 in sequence.

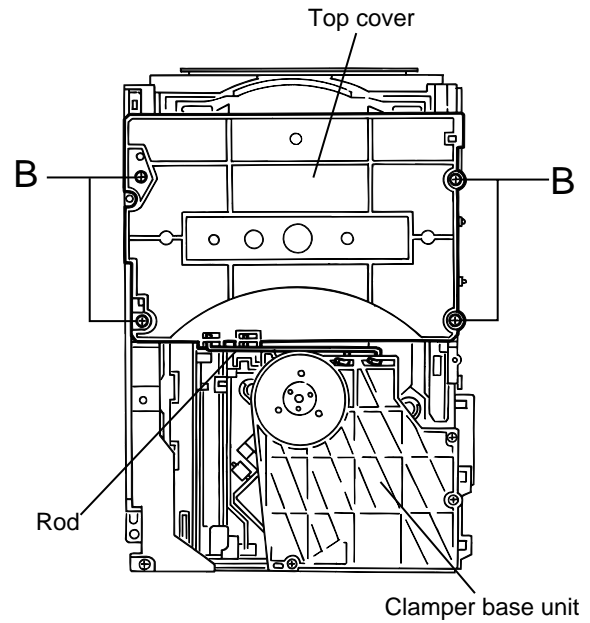

Fig.5

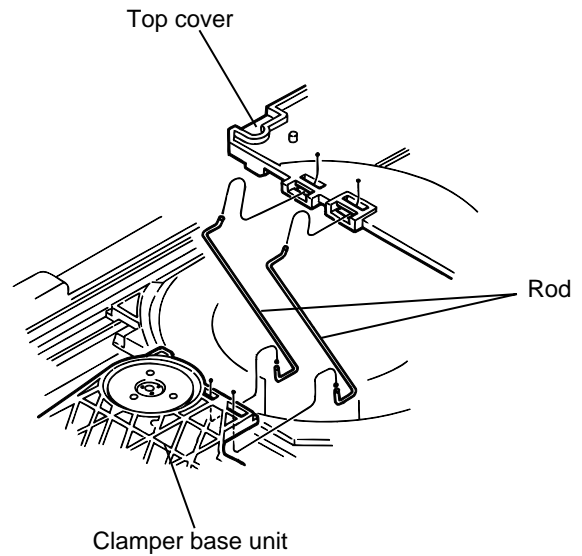

Fig.6

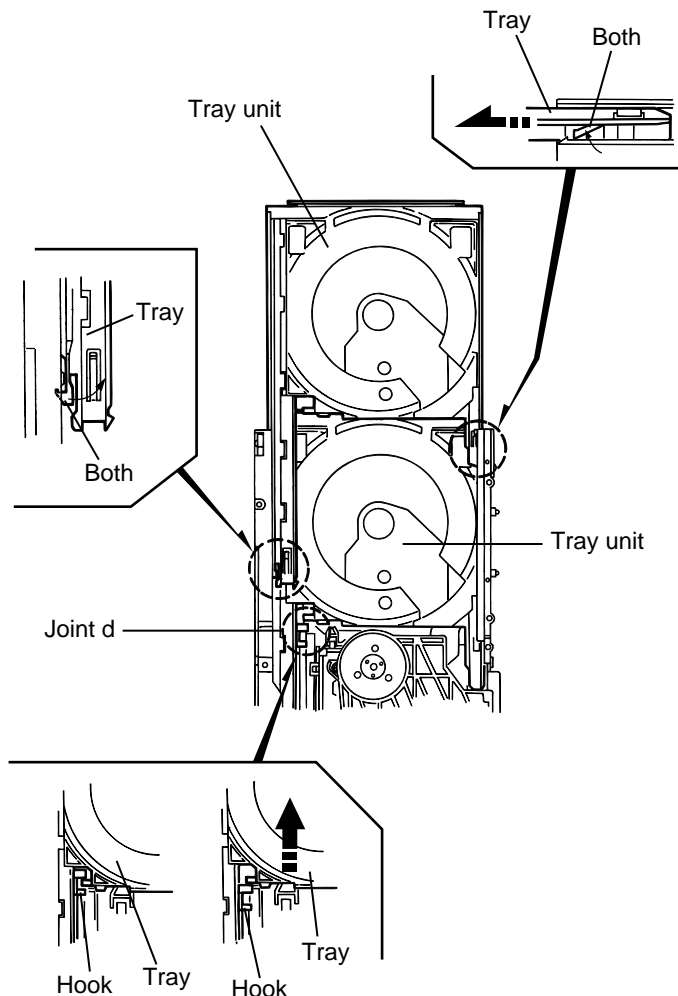

Fig.8

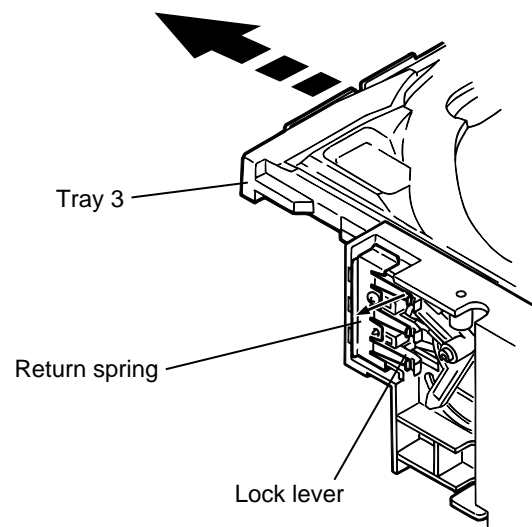

Fig.7

■ **Removing the side unit (L) and (R)**
 (See Fig.9-1 to 9-5)

• Prior to performing the following procedures, remove the servo control board, the top cover and the tray unit.

1. Remove the two screws C attaching the side unit (L).
2. Slide and remove the side unit (L) toward the front while releasing the two joints e and the joint f with the chassis unit.
3. Slide the slide cam (L) toward the front until it stops to place the sub chassis unit at the top position.

ATTENTION: The side unit (R) can be removed when the sub chassis unit is located at the top position.

4. Turn the hook gear counterclockwise to move the slide hook and the slider (R) backward until they stop.
5. Remove the three screws D attaching the side unit (R). Raise the side unit (R) upward and release the joint g with the chassis unit and the boss from the select arm marked h. Then remove the side unit (R) from the body.

ATTENTION: When reassembling, make sure the boss is fitted to the select arm marked h.

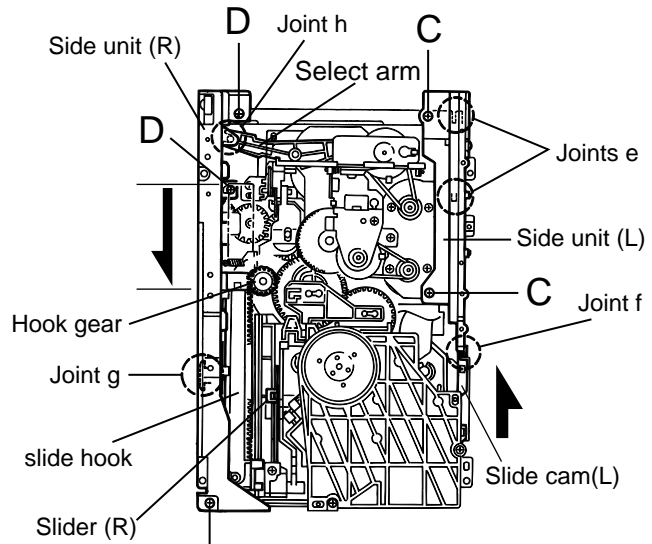

Fig.9-1

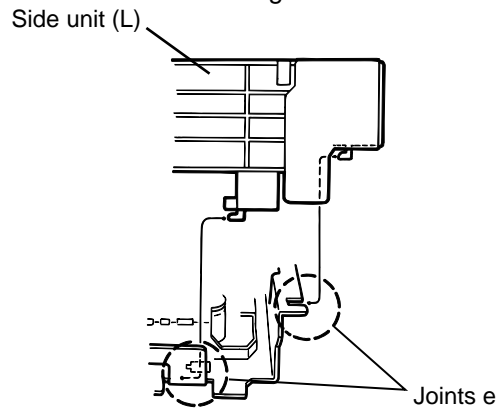

Fig.9-2

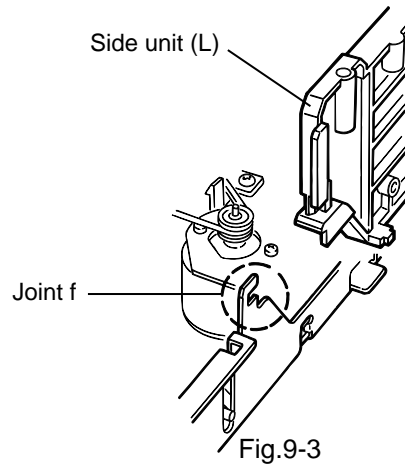

Fig.9-3

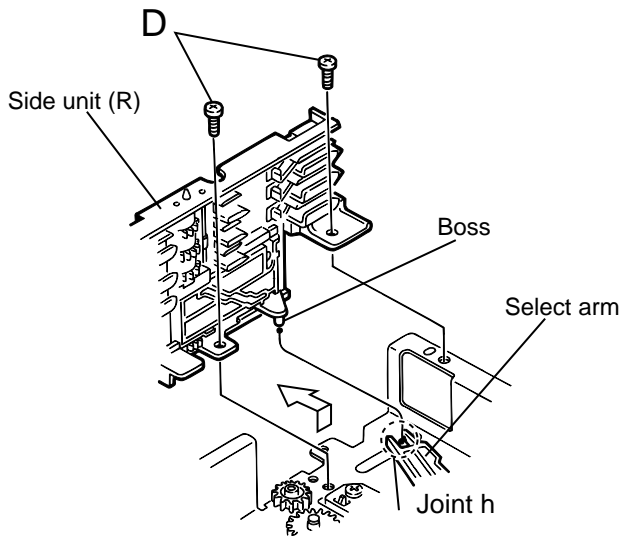

Fig.9-4

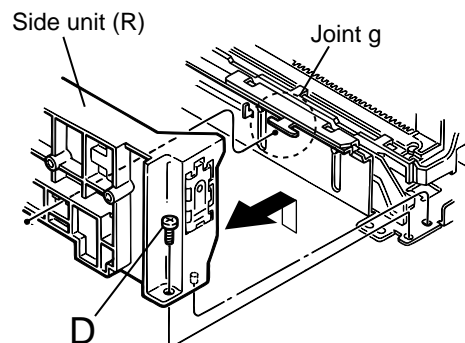

Fig.9-5

■ **Removing the sub chassis unit**
(See Fig.10 to 12)

• Prior to performing the following procedures, remove the servo control board, the top cover, the tray unit, the side unit (L) and the side unit (R).

1. Turn the hook gear counterclockwise to move the slide hook and the slider (R) backward until they stop.
2. Slide the slide cam (L) and the slide cam (R) in the direction of the arrow until they stop.

(The notches of each slide cam are fitted to the pins on both sides of the sub chassis unit.)

3. Detach the sub chassis unit upward.

ATTENTION: When reassembling, turn the hook gear of the chassis unit counterclockwise until it stops and slide the slide hook and the slider (R) of the sub chassis unit backward until they stop.

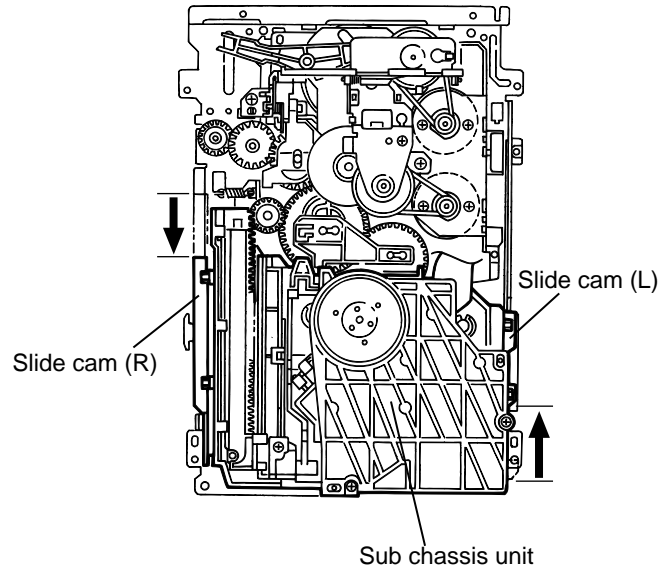

Fig.10

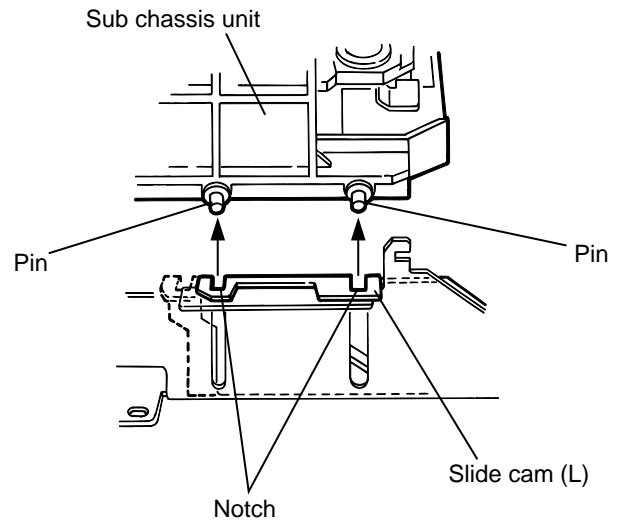

Fig.11

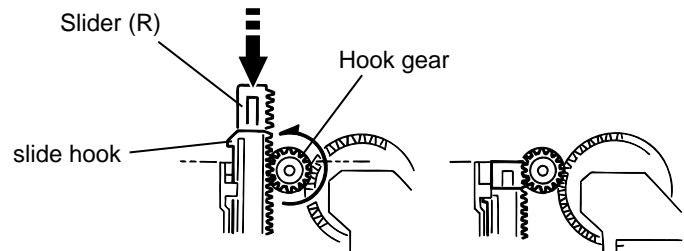

Fig.12

■ Removing the flap base unit and the gear base unit (See Fig.13 and 14)

• Prior to performing the following procedures, remove the servo control board, the top cover, the tray unit, the side unit (L) and the side unit (R).

1. Remove the screw E attaching the flap base unit. Release the joint tabs i and j, then remove the flap base unit from the body.
2. Remove the belts from the two pulleys on the gear base unit.
3. Remove the three screws F and remove the gear base unit from the body.

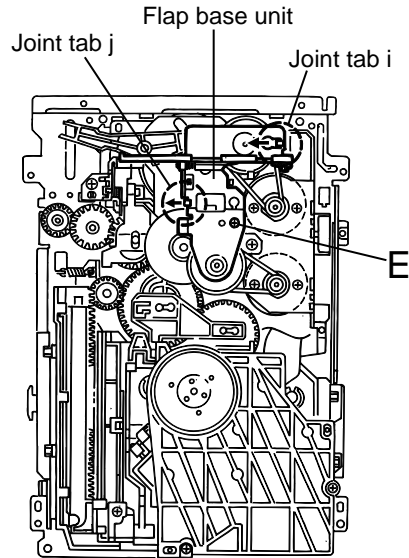

Fig.13

■ Removing the motors (See Fig.15)

• Prior to performing the following procedure, remove the main board.

1. Remove the belts from the two pulleys.
2. Remove the four screws G and detach each motor from the body.

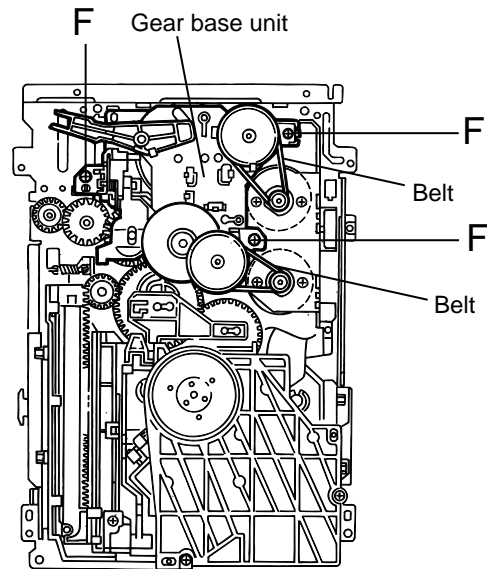

Fig.14

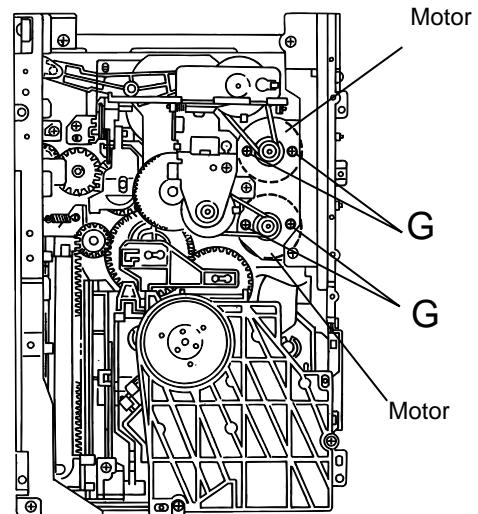

Fig.15

■ Removing the pickup (See Fig.16 to 20)

1. From the top of the body, remove the three screws H attaching the clamper base unit.
2. Remove the clamper base unit with the two rods attached to the clamper base unit and the top cover.
3. Turn the screw shaft gear marked k in the direction of the arrow to move the pickup unit.
4. Remove the screw I attaching the shaft holder.
5. Move the screw shaft in the direction of the arrow and release it from the joint I. Then release it from the joint m with the pickup holder. Detach the pickup with the screw shaft.
6. Solder the part n of the flexible board on the underside of the pickup. After soldering, disconnect the flexible wire connected to the pickup (In case of disconnecting the flexible wire without soldering, it may cause damage to the CD pickup).
7. Remove the two screws J attaching the rack arm to the pickup unit.
8. Pull out the screw shaft from the pickup.

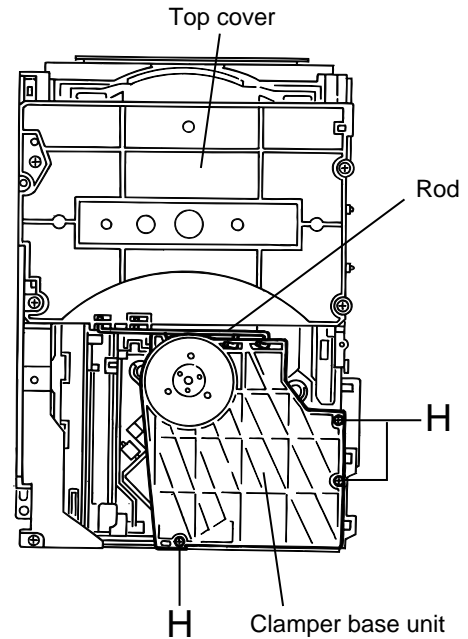

Fig.16

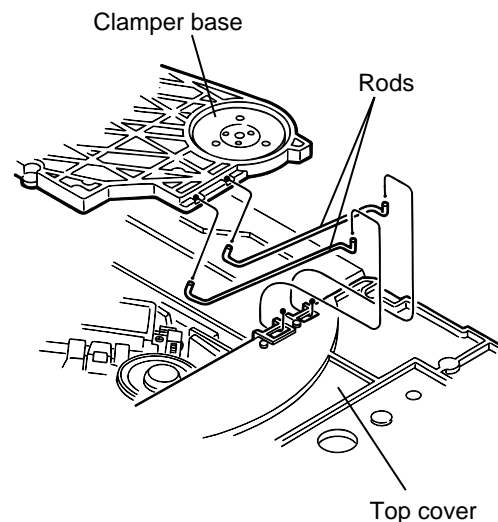

Fig.17

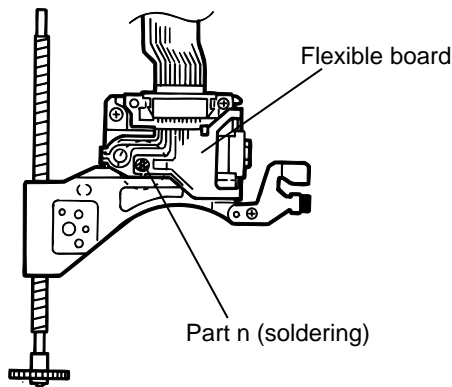

Fig.19

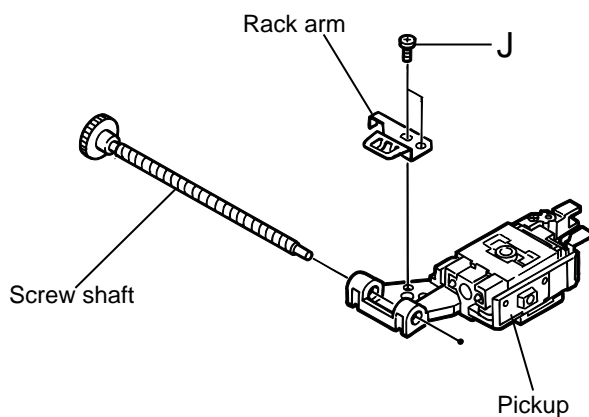

Fig.20

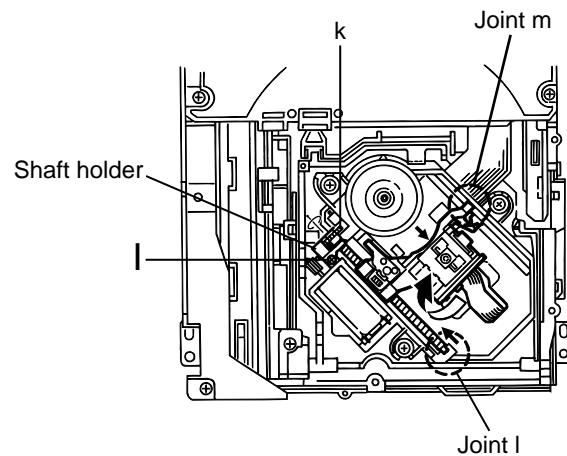

Fig.18

■ **Removing the traverse mechanism assembly (See Fig.21)**

• Prior to performing the following procedure, remove the servo control board and the clamper base unit.

1. Remove the three screws K attaching the traverse mechanism assembly.
2. Detach the rear part of the traverse mechanism assembly upward to release the joint o with the sub chassis unit. Then remove the assembly from the body.

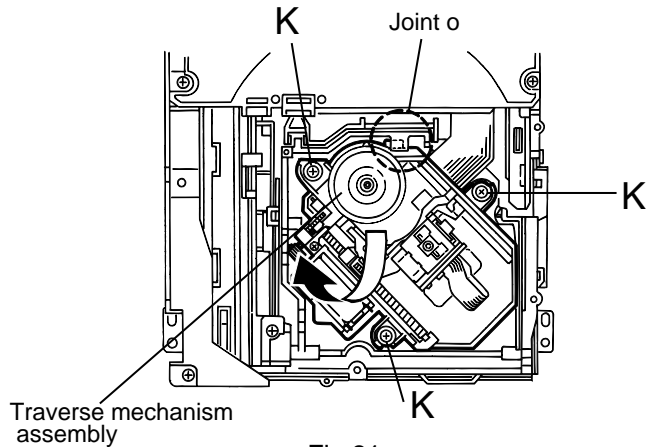

Fig.21

■ **Removing the feed motor (See Fig.22)**

• Prior to performing the following procedure, remove the traverse mechanism assembly.

1. Remove the screw L attaching the feed motor.

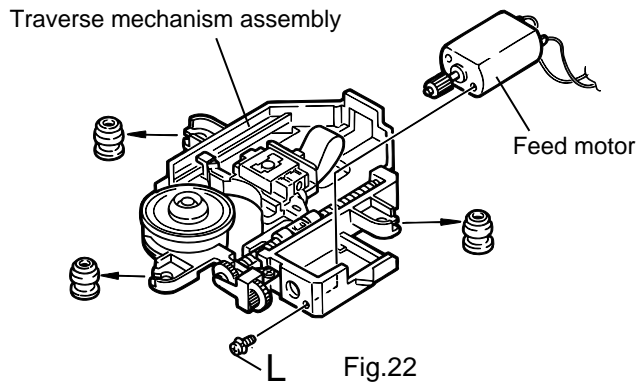

Fig.22

■ **Removing the tray select switch board (See Fig.5,6 and 23)**

1. Remove the four screws B attaching the top cover on the top of the body.
2. Remove the top cover with the two rods attached to the top cover and the clamper base unit.
3. Remove the screw M on the right side of the body.

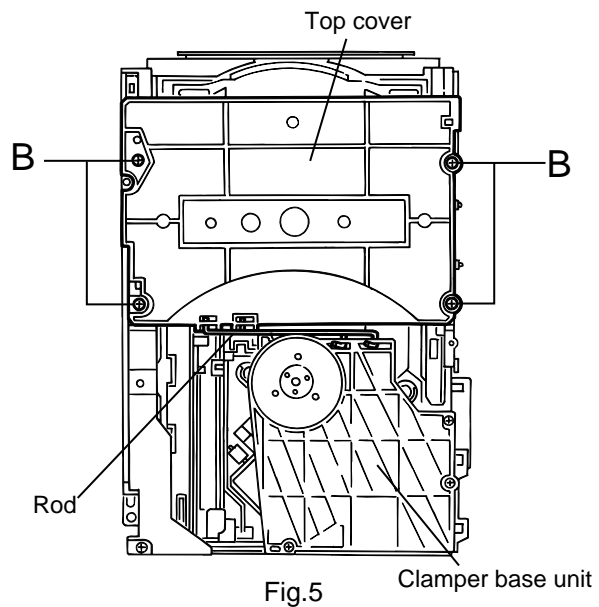

Fig.5

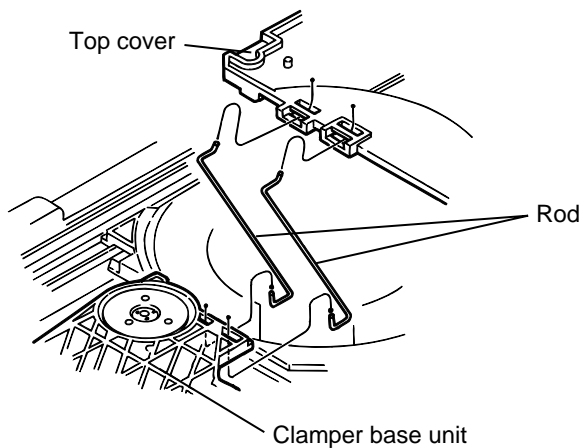

Fig.6

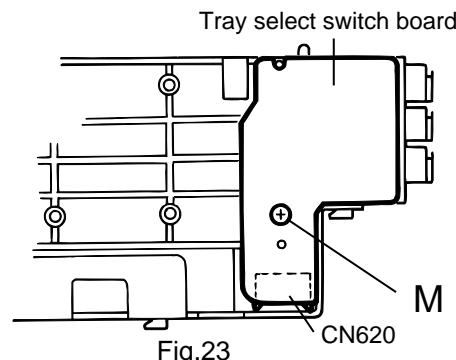

Fig.23

<Speaker section>

Information

This is a method of dis assembly.
As parts of the repair of this speaker system, it is only the speaker box assemblies.
It is not possible to supply with each part unit.

- Prior to performing the following procedure, remove the front grille.

■ Removing the speaker (woofer) (See Fig.1,3 to 5)

1. Insert a screwdriver under the ornament grille attached to the woofer.
2. Pull out the ornament grille with each boss by means of a lever as shown in Fig.2.

ATTENTION: As the ornament grille is damaged, replace it with the woofer.

ATTENTION: When replacing the ornament grille, make sure the boss with adequate amount of bond.

3. Remove the four screws **A** and the woofer from the body. Disconnect the wire from the speaker terminals.

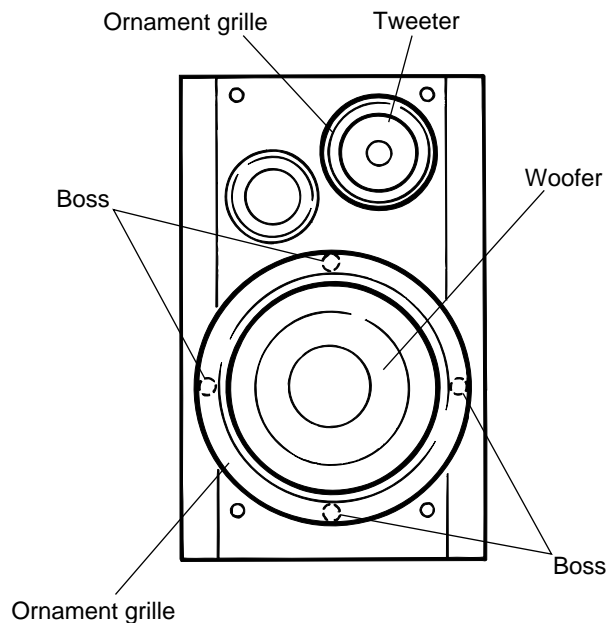

Fig.1

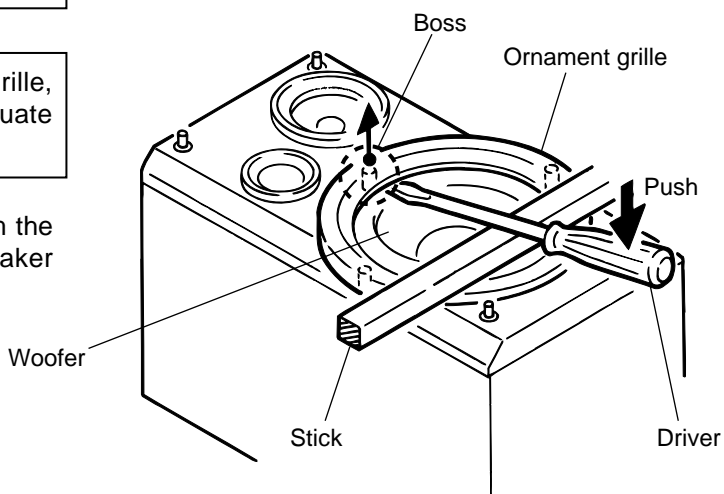

Fig.2

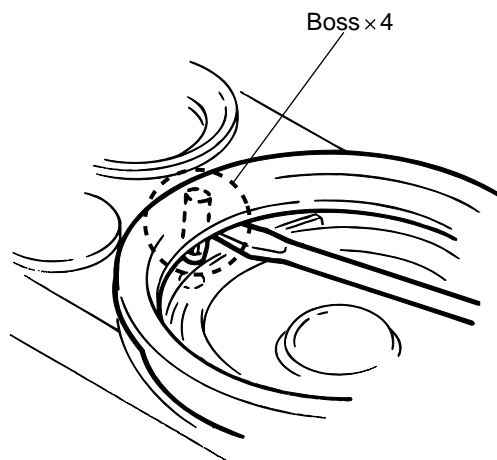

Fig.3

■ Removing the speaker (tweeter) (See Fig.4 and 5)

1. Insert a screwdriver under the ornament grille and remove it from the body.

ATTENTION: As the ornament grille is damaged, replace it with the tweeter.

3. Remove the three screws **B** and the tweeter from the body. Disconnect the wire from the speaker terminals.

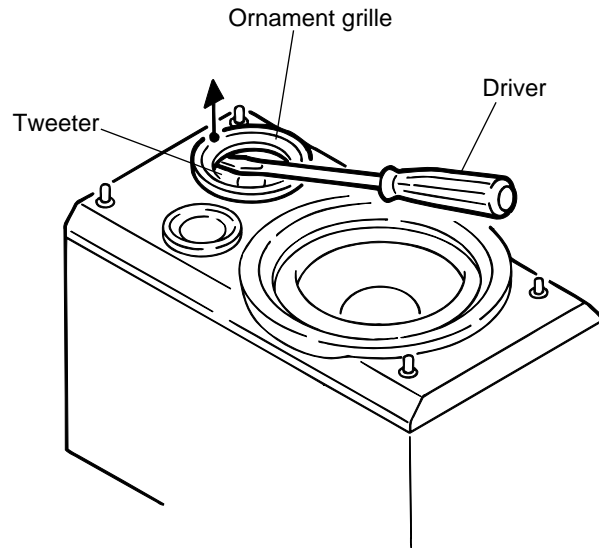

Fig.4

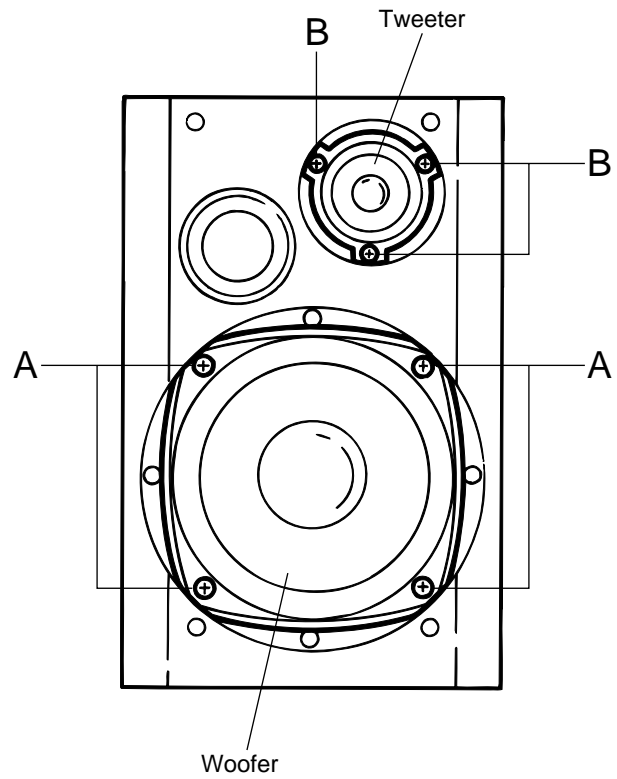

Fig.5

Adjustment method

※ This model is auto adjust system.

MD TEST MODE 1

1.Setting the TEST MODE1

(CAUTION) MD mode should NO DISC condition, when POWER ON to not read TOC.

Press [STOP ■ key] and [CANCEL key] together, and connect the power cord.

LCD indication
MD TEST MODE 1

Setting the MD TEST MODE1
by press [POWER key]

LCD indication
[HELLO] then
[MD TEST MODE 1]

Setting OK

2.Initialize the EEPROM

Setting the MD TEST MODE 1

Press [REC PAUSE key]
of the Remote controller

LCD indication
DATA INITIAL

Initialize OK

3.Laser power adjustment

Insert the sensor
of laser power meter

Press [2 key] of
Remote controller

LCD indication
L.POWER PLAY

Adjust the PLAYBACK
laser power

Laser power up by [▶▶▶ key]
of Remote controller

Laser power down by [◀◀◀ key]
of Remote controller

LCD indication
L.POWER UP

LCD indication
L.POWER DOWN

0.68mW ≥ Adjustment

Press [STOP key] of
Remote controller

Playback laser power
adjustment complete

Press [4 key] of
Remote controller

LCD indication
L.POWER REC

Adjust the RECORDING
laser power

Laser power up by [▶▶▶ key]
of Remote controller

Laser power down by [◀◀◀ key]
of Remote controller

LCD indication
L.POWER UP

LCD indication
L.POWER DOWN

6.23mW ≤ Adjustment

Press [STOP key] of
Remote controller

Press [EJECT key]
of main body

Adjustment complete

4.Disc adjustment

This adjustment should done after laser power adjustment.

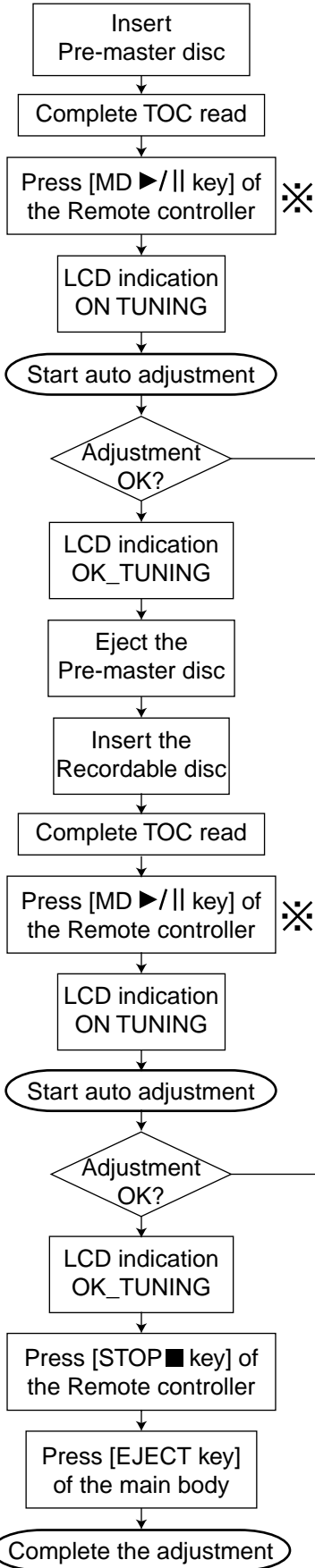

✖ [CAUTION] Please push the [STOP key] to remote control when the LCD display becomes [NG ERROR], and push the [MD ▶/||key] to remote control again.

LCD indication
NG_ERR ** _!
<Refer the NG code list>

<NG code list>

CODE	Adjustment NG section
00	Auto adjustment not complete
01	REST switch detection
02	FOCUS ON
03	PIT section EF balance, tracking offset adjustment
04	PIT section ABCD level (IV impedance) adjustment
05	PIT section focus servo AGC
06	PIT section tracking servo AGC
07	PIT section focus bias adjustment
08	GRV section EF balance, tracking offset adjustment
09	GRV section ABCD level (IV impedance) adjustment
0A	GRV section focus servo AGC
0B	GRV section tracking servo AGC
0C	GRV section focus bias adjustment
0D	Room temperature
0E	EEPROM writing
FF	Auto adjustment complete (OK)

LCD indication
NG_ERR ** _!
<Refer the NG code list>

5.Independent operation mode

In case the checking mode or adjustment when occur the error at disc adjustment, Independent mode into by select the key before release the TERST MODE.

Operation key	MODE
Remote controller [SLEEP]	Focus search [FOCUS_SEARCH]
Remote controller [6 key]	Pit rough servo [P.R.SERVO]
Remote controller [7 key]	Groove rough servo [GR.R.SERVO]
Remote controller [8 key]	Tracking ON [TRACKING_ON]
Remote controller [9 key]	Tracking OFF [TRACKING_OFF]
Remote controller [STOP]	STOP [STOP]
Main body [EJECT]	EJECT [EJECT]

MD TEST MODE 2

1.Setting the TEST MODE 2

(CAUTION) MD mode should NO DISC condition, when POWER ON to not read TOC.

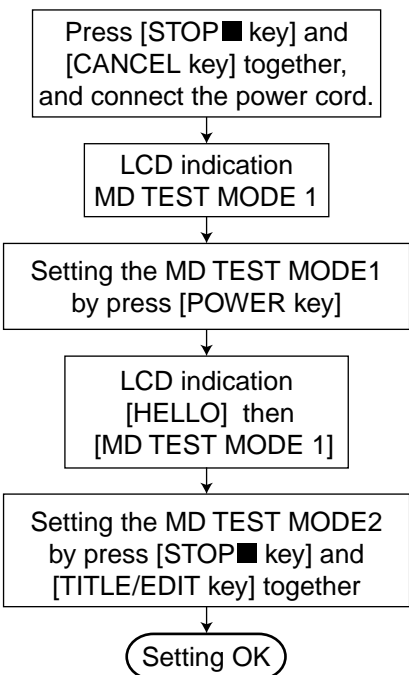

2.Indication the drift level of the pickup adjustment value

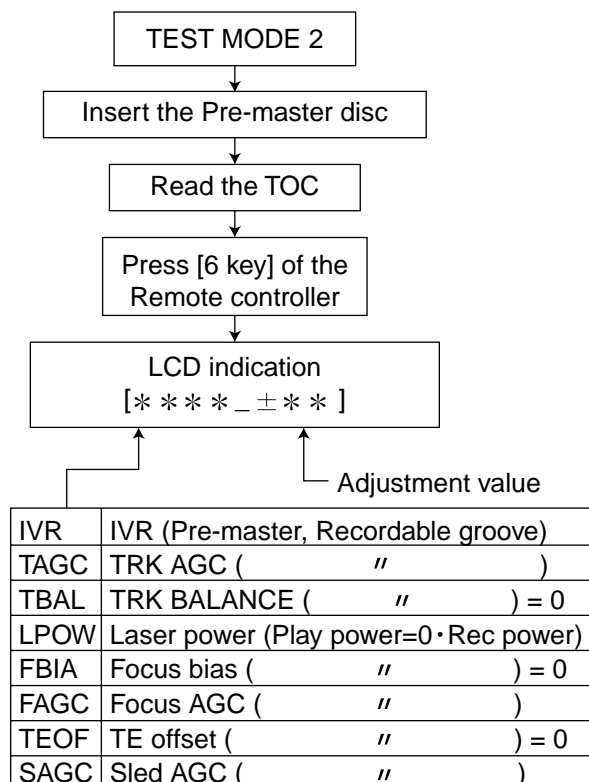

3.Indication the C1 ERROR

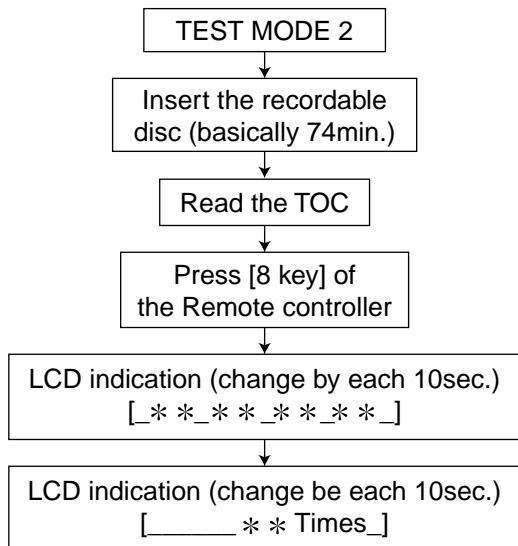

4.Release the MD TEST MODE

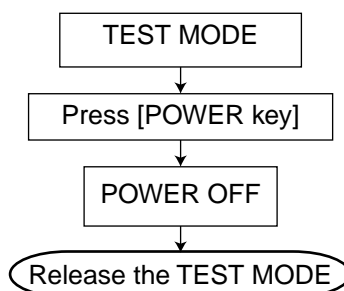

CD TEST MODE

CD section is no need the adjustment by design.

1.Setting the TEST MODE

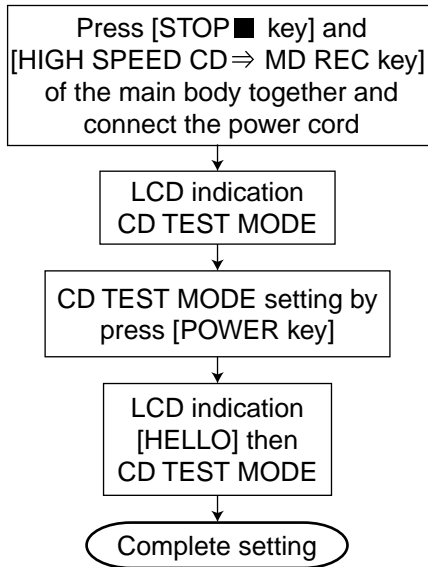

2.Indication the C1 ERROR

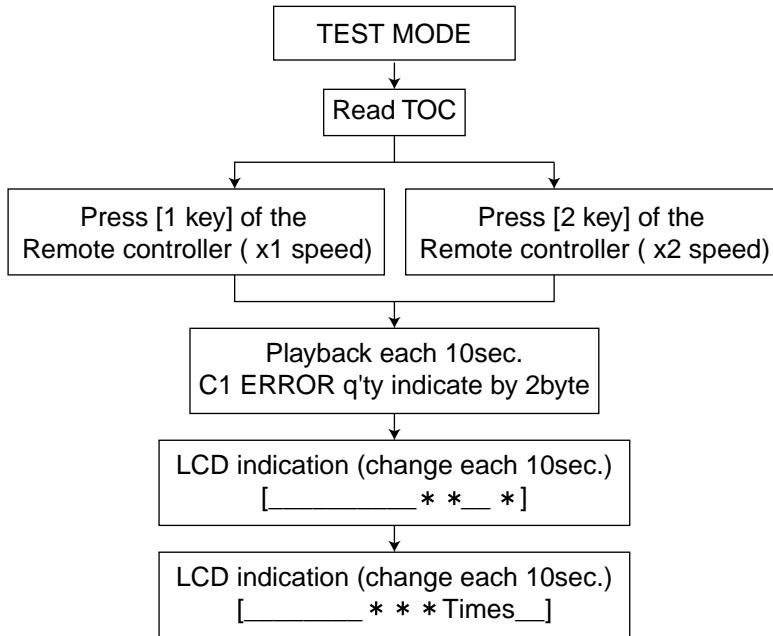

3.Release the CD TEST MODE

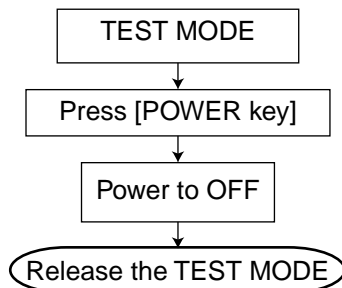

LCD ALL INDICATION, TIME COMPRESSION TEST MODE

1.Setting the TEST MODE

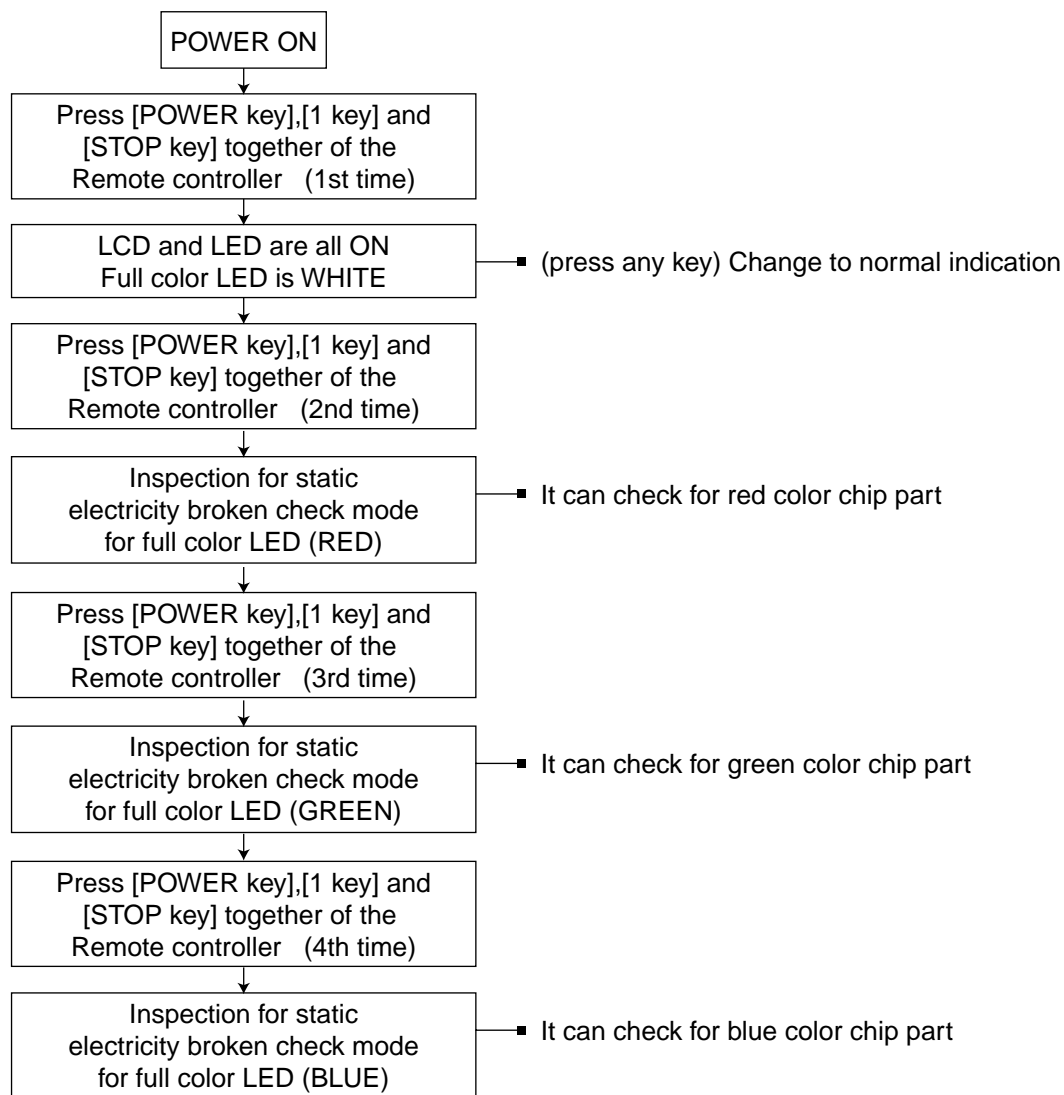

Caution:Full color LED is keep white condition, when loop out by any key at test mode.

2.Fast forward of CLOCK/SLEEP TIMER

Including the ALL LED ON mode and Static electricity broken thes, clock count up is change to 1min. to 1sec.

Check for only [CLOCK mode] and [SLEEP TIMER].

3.Release the TEST MODE

TEST MODE is release by disconnect the AC power cord.

RUNNING MODE

This running mode is a mode by which the recording is compulsorily deleted with ALL-ERASE after U-TOC is written when the recording of MD ends, and the recording is repeated again.
 This TEST MODE is continue recording (loop recording), it is for recording stop when MD end.
 This TEST MODE is only can use manual operation recording [MD REC PAUSE]. CD synchro recording (CD→MD REC,BEST HIT REC,1CD→ MD REC) is not operate correctly.

1.Setting the TEST MODE

- 1:Setting normal speed recording mode by pressing together [POWER key], [2 key] and [STOP key] of Remote controller.
 - 2:If normal speed mode is default then change to high speed mode, press [HIGH SPEED CD>MD key] of main body before recording start.
 - 3:Once change to high speed mode, TEST MODE is continue until release.
 - 4:Return to normal speed recording mode, it should release the TEST MODE then resetting the TEST MODE.
- (REMARKS) Case of CD high speed recording : After setting TEST MODE, if it need setting CD play mode or repeat mode. Press [HIGH SPEED CD > MD key] setting high speed mode. RUNNING MODE is start by REC STANDBY (indicate [RUNNING MODE] on LCD) at [MD REC PAUSE key] then playback the CD.
 (During recording, LCD indicate [RUNNING MODE])

2.Release the TEST MODE

Test mode is release by POWER OFF.

Indication the [CAUTION !] when abnormal

1.Detect the abnormal condition of stability power supply

Abnormal detection dine of the stability power supply(REG.) at CPU [SAFETY1~3] port (IC801:6,7,9pin), when system CPU (IC801) supply voltage (US D5.6V) is normal condition.
 Watching the abnormal at POWER ON condition, if detect the abnormal indicate [CAUTION!] and come under stability power supply (8V/10V or 12V OR 6V), and indicate [DATA(HEX)] of the abnormal port voltage then power off to forcibly.

Detect the abnormal condition of stability power supply is next.

[8V/10V] : SAFETY1 port (Power supply of full color LED/Power supply of CD mechanism)

[12V] : SAFETY2 port (Power supply for tuner module REG, MD mechanism REG, volume IC, LPF IC and CD/MD SELECTOR)

[6V] : SAFETY3 port (Power supply for MD mechanism, power supply for OPT. module, power supply for CD/OPT SELECTOR)

* (REMARKS) Safety port voltage at detect the abnormal condition.

DATA(HEX)	PORT voltage	Detect condition
3FF~2D0	5.0~3.52V	Abnormal (Power off at 1sec. forcibly)
2CF~12C	3.515~1.456V	Normal
12B~000	1.46V~0V	Abnormal (Power off at 3sec. forcibly)

2.Abnormal detection of CD mechanism

When detect the abnormal condition of CD mechanism, indicate [CAUTION !] and come under condition and back light is change to [RED] forcibly.

Indication when mechanism abnormal condition.

[CD INITIAL] : Abnormal condition when mechanism initialize after power cord to connect to AC outlet then power to ON.

[CD MECH] : Abnormal condition when mechanism initialize at return operation, it is Sub Tray Load/Unload operation, Lifter shift operation, or CAM operation are defect.

[CD MECHA 5V] : Abnormal condition at 5V (LSI) internal the CD mechanism.

Flow of functional operation until TOC read (MD section)

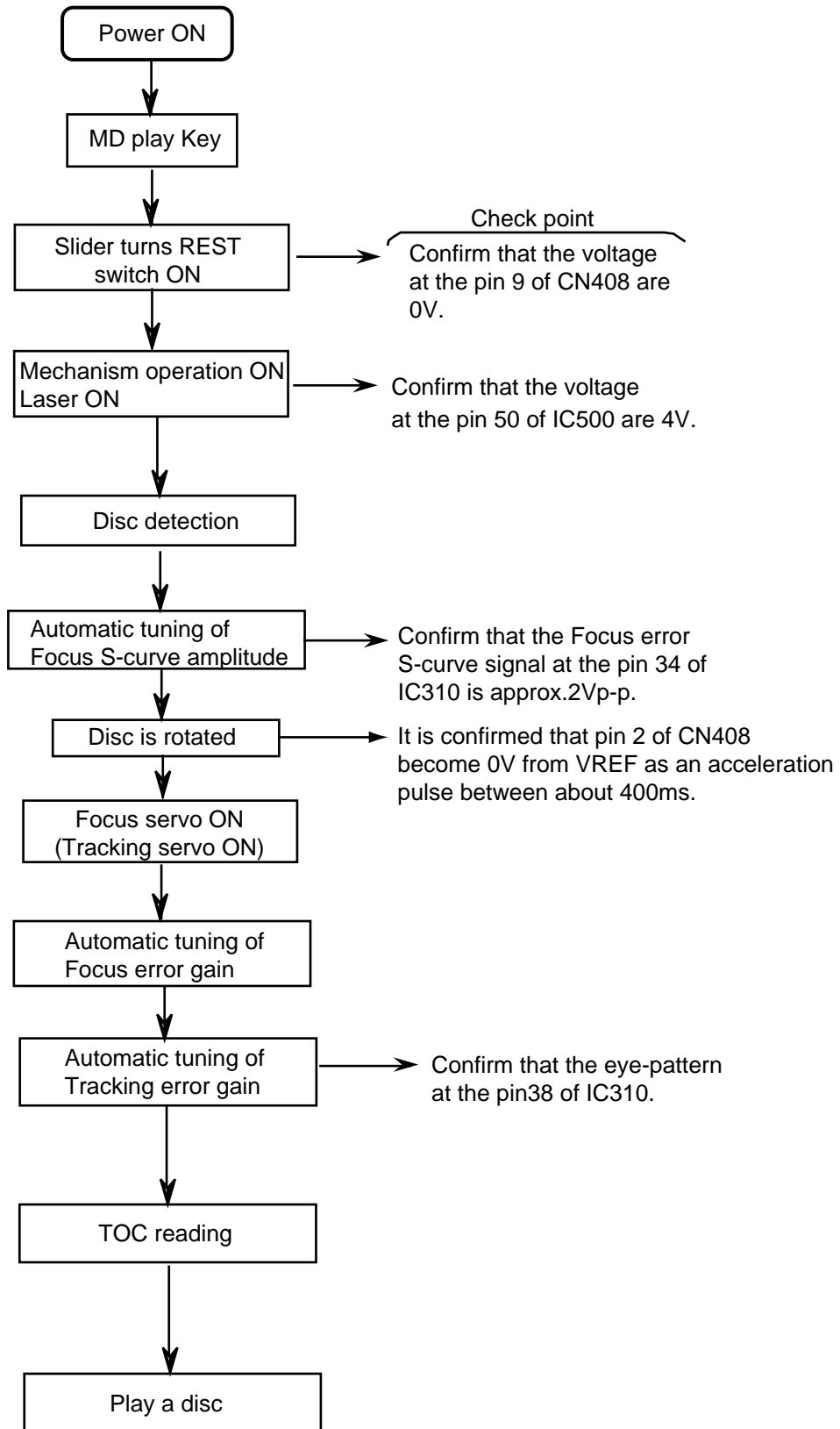

Maintenance of laser pickup (MD)

1. Cleaning of pickup lens

- (1) Prior to changing the pickup, clean the pickup lens.
- (2) For cleaning the lens, use the following cotton swab after mearsing it in alcohol.
Product No : JCB-B4 Manufacturer : Nippon Cotton Swab

2. Confirmation of the service life of laser diode when the service life of the laser diode has been exhausted, the following symptoms will appear.

- (1) Recording will become impossible.
- (2) The RF output (EFM output and eye-pattern amplitude) will become lower.
- (3) The drive current required for light emitting of laser diode will be increased.

Confirm the service life according to the following flow chart.

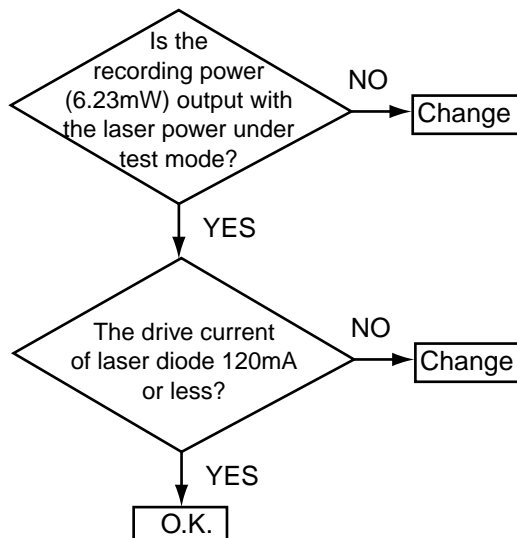

3. Method of measuring the drive current of laser diode

When the voltage measured at each side of R337, it become 120mV or over, the service life of laser diode is judged to have been exhausted.

Replacement of laser pickup (MD)

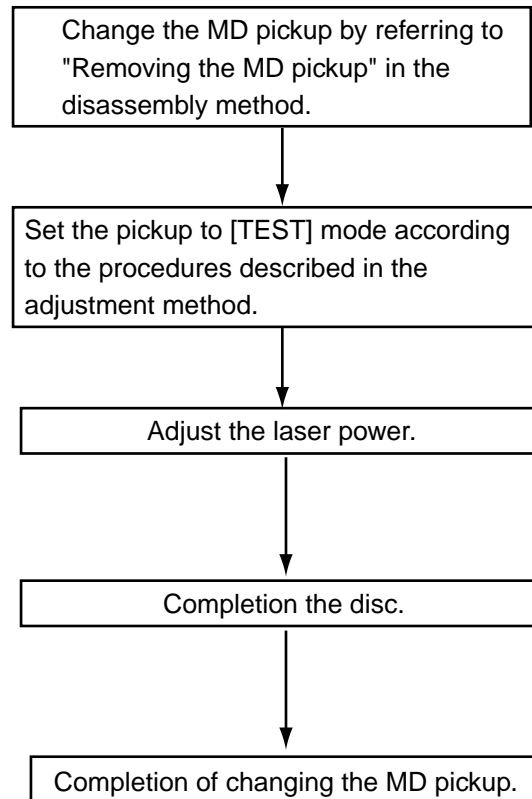

CAUTION

Since this system is designed to perform magnetic recording, the laser power ten times or over of the conventional MD player will be output. Therefore, be sure to perform not only adjustment and operation of this system so carefully as not to directly look at the laser beam or touch on the body.

4.Semi-solid state resistors on the APC board.

The semi-solid state resistor on the APC board attached to the pickup is used for adjusting the laser power. Since these resistor should be adjusted in pair according to the characteristics of the optical block, be sure not touch on the resistors. Since the service life of the laser diode will be exhausted when the laser power is low, it is necessary to change the pickup. Meanwhile, do not pickup. Otherwise, the pickup will be damaged due to over current.

Flow of functional operation until TOC read (CD section)

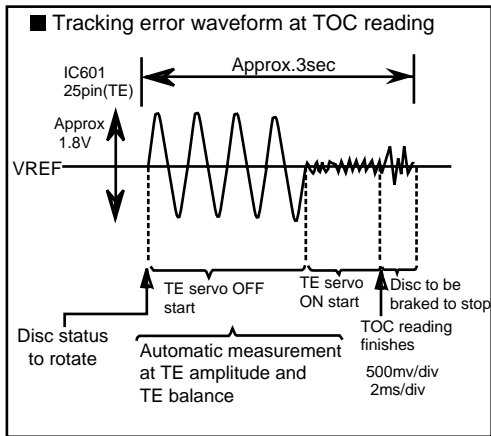
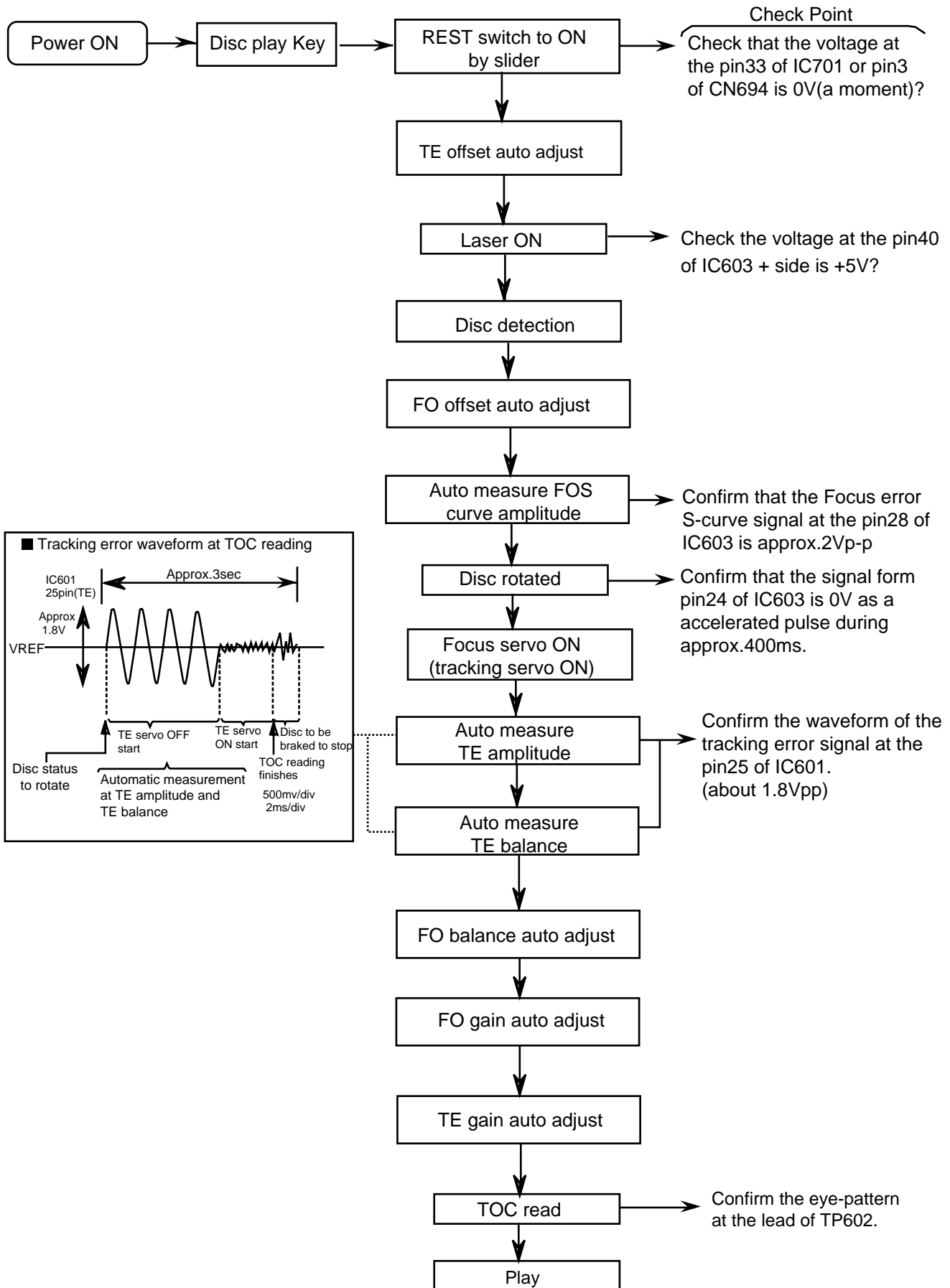

Maintenance of laser pickup (CD)

(1) Cleaning the pickup lens

Before you replace the pickup, please try to clean the lens with a alcohol soaked cotton swab.

(2) Life of the laser diode

When the life of the laser diode has expired, the following symptoms will appear.

- (1) The level of RF output (EFM output : amplitude of eye-pattern) will below.

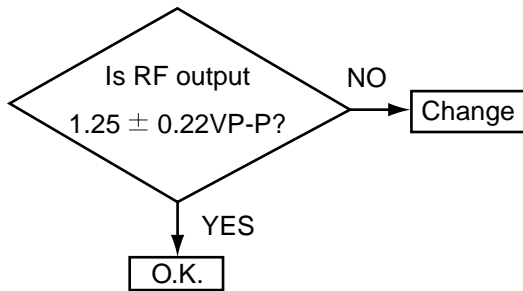

(3) Semi-fixed resistor on the APC board

The semi-fixed resistor on the APC board which is attached to the pickup is used to adjust the laser power.

Since this adjustment should be performed to match the characteristics of the whole optical block, do not touch the semi-fixed resistor.

If the laser power is lower than specified value, the laser diode is almost worn out, and the pickup should be replaced.

If the semi-fixed resistor is adjust while the pickup is functioning normally, the laser pickup may be damaged due to excessive current.

Replacement of laser pickup (CD)

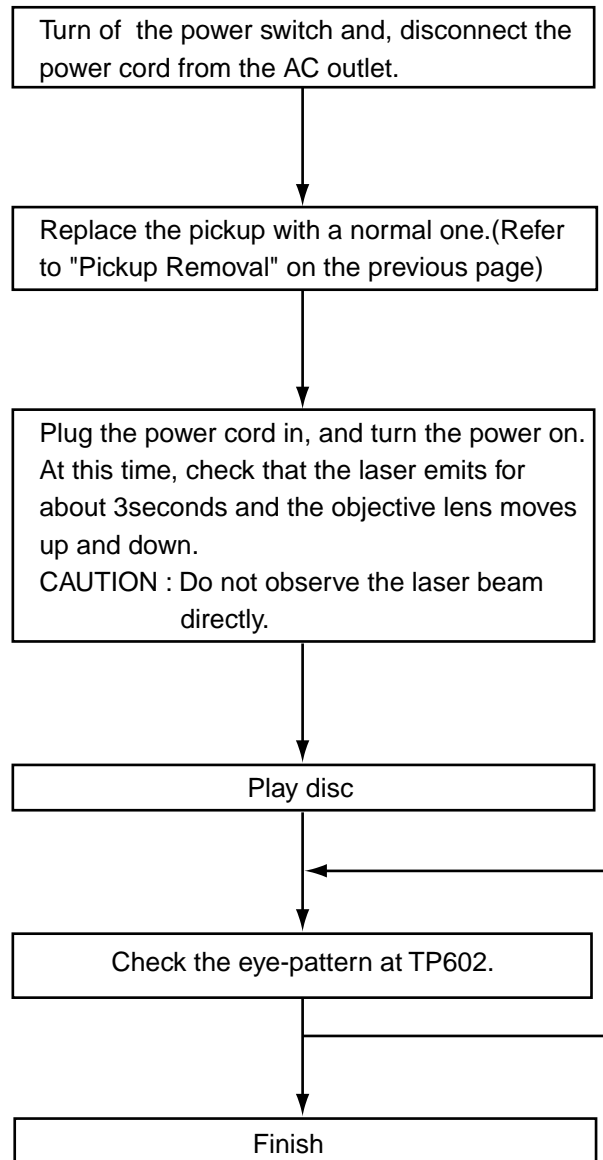

Description of major ICs

■ AK4519VF-X (IC480) : A / D D / A converter

1.Pin layout



2.Block diagram

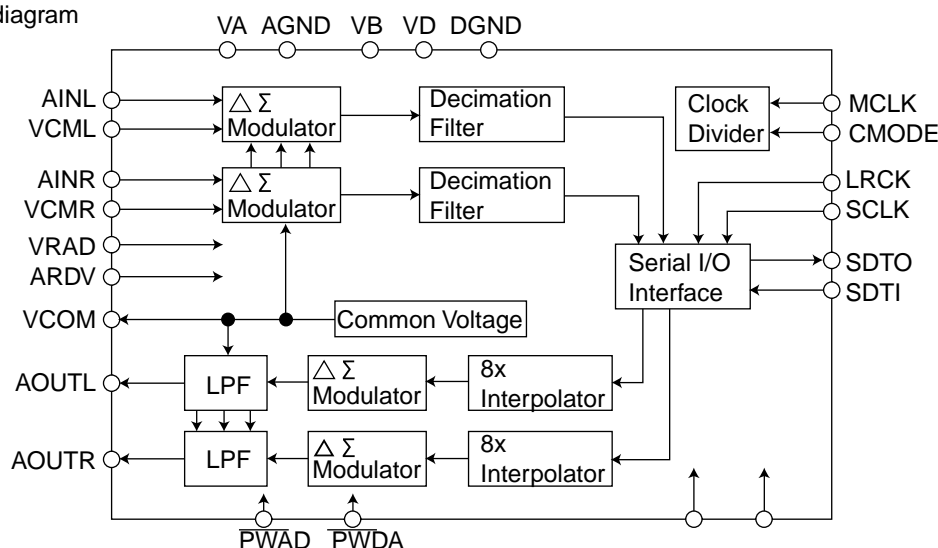

3.Pin Function

Pin NO.	Symbol	I/O	Function
1	VRDA	I	Voltage Reference Input Pin for DAC, VA
2	VRAD	I	Voltage Reference Input Pin for ADC, VA
3	AINR	I	Rch Analog Input Pin
4	VCMR	O	Rch Common Voltage Output Pin, 0.45xVA
5	VCML	O	Lch Common Voltage Output Pin, 0.45xVA
6	AINL	I	Lch Analog Input Pin
7	PWAD	I	ADC Power-Down Mode Pin "L":Power Down
8	PWDA	I	DAC Power-Down Mode Pin "L":Power Down
9	MCLK	I	Master Clock Input Pin
10	LRCK	I	Input/Output Channel Clock Pin
11	SCLK	I	Audio Serial Data Clock Pin
12	SDTO	O	Audio Serial Data Output Pin
13	DGND	-	Digital Ground Pin
14	VD	-	Digital Power Supply Pin
15	SDTI	I	Audio Serial Data Input Pin
16	CMODE	I	Master Clock Select Pin
17	DEM1	I	De-emphasis Frequency Select Pin
18	DEM0	I	De-emphasis Frequency Select Pin
19	AOUTL	O	Lch Analog Output Pin
20	AOUTR	O	Rch Analog Output Pin
21	VCOM	O	Common Voltage Output Pin, 0.45xVA
22	AGND	-	Analog Ground Pin
23	VB	-	Substrate Pin
24	VA	-	Analog Power Supply Pin

■ AN8849SB-W (IC601) : Head amp

1.Pin layout

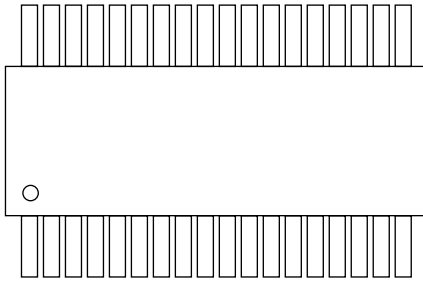

2.Block diagram

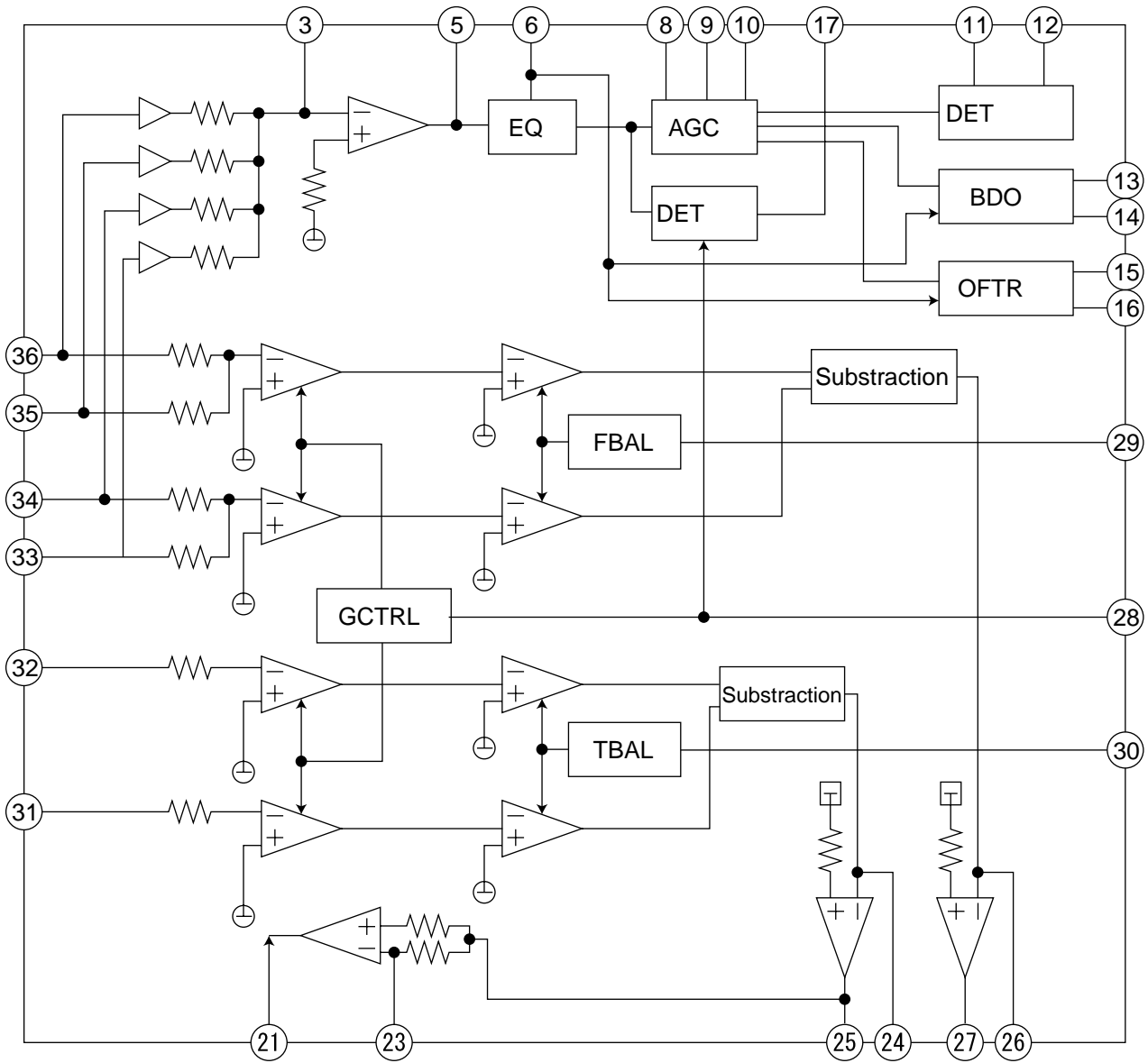

3.Pin Function

Pin NO.	Symbol	Function
1	PD	Photo detector signal input.
2	LD	Laser diode drive terminal.
3	RFN	RF amp negative input terminal.
4	Vcc1	Power supply terminal.
5	RFOUT	Equaruzer connect terminal.
6	EQSW	Power supply terminal.
7	Vcc2	RF AGC input terminal.
8	RFC	RF AGC filter connect terminal.
9	CAGC	ARF output terminal.
10	ARF	3T envelope detect filter terminal.
11	CEA	Envelope detect output circuit.
12	ENV	Low level DO detect connect terminal.
13	CBDO	DO detect signal output terminal.
14	BDO	OFF TRACK detect signal connect terminal.
15	COFTR	OFF TRACK detect signal output terminal.
16	OFTR	RF signal amp. detection output.
17	NRFDET	Ground.
18	GND	LD APC ON / OFF select.
19	LDON	Reference voltage output terminal.
20	VREF1	CROSS detect signal output terminal.
21	CROSS	Reference voltage output terminal.
22	VREF2	CROSS detect filter connect terminal.
23	CCRS	Tracking error output terminal.
24	TEN	TE amp.negative input terminal.
25	TEOUT	FE amp.negative input terminal.
26	FEN	Focus error output terminal.
27	FEOUT	Focus gain, tracking gain adjust control signal inout terminal.
28	GCTRL	Focus barance adjust control input terminal.
29	FBAL	Tracking barance adjust control input terminal.
30	TBAL	Connect PDIC.
31	E	Connect PDIC.
32	F	Connect PDIC.
33	D	Connect PDIC.
34	B	Connect PDIC.
35	C	Connect PDIC.
36	A	Connect PDIC.

■ CXA2523AR (IC310) : MD servo

1. Block diagram

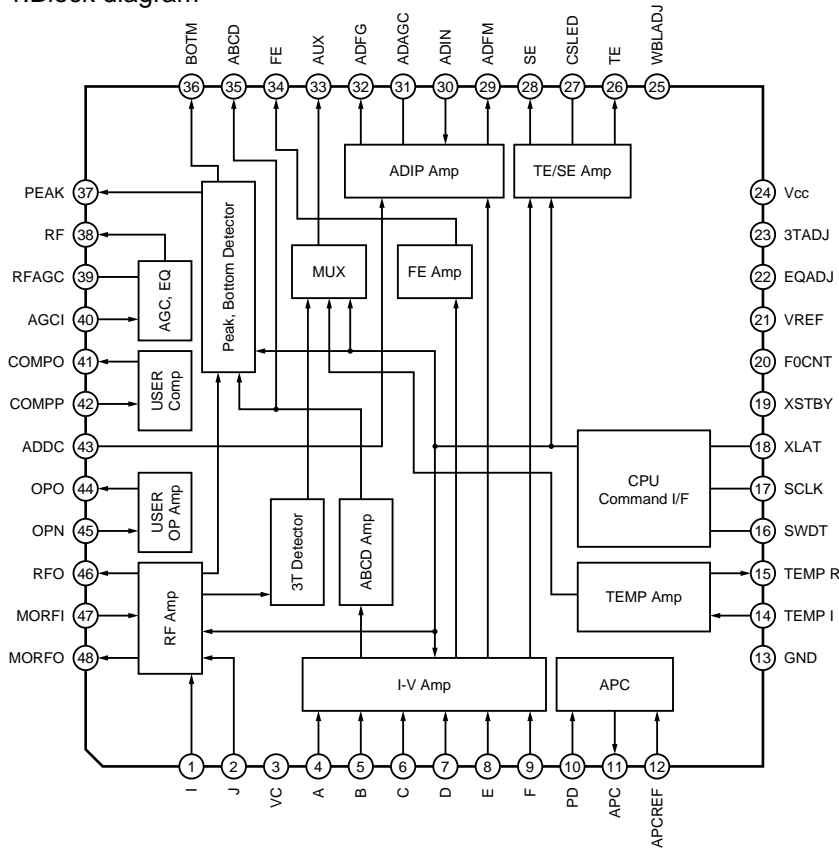

2. Pin function

Pin No.	Symbol	I/O	Function
1	I	I	I-V converted RF signal I input.
2	J	I	I-V converted RF signal J input.
3	VC	O	Vcc/2 voltage output.
4	A	I	A current input for main beam servo signal.
5	B	I	B current input for main beam servo signal.
6	C	I	C current input for main beam servo signal.
7	D	I	D current input for main beam servo signal.
8	E	I	E current input for side beam servo signal.
9	F	I	F current input for side beam servo signal.
10	PD	I	Reflection light quantity monitor signal input.
11	APC	O	Laser APC output.
12	APCREF	I	Reference voltage input for the laser power intensity setting.
13	GND	-	Connect to GND.
14	TEMPI	I	Connects the temperature sensor.
15	TEMP R	I	Connects the temperature sensor. outputs the reference voltage.
16	SWDT	I	Data input for microcomputer serial interface.
17	SCLK	I	Shift clock input for microcomputer serial interface.
18	XLAT	I	Latch signal input for microcomputer serial interface. Latched when low.
19	XSTBY	I	Standby setting pin. Normal operation when high Standby when low.
20	F0CNT	I	Internal current source setting pin.

Pin No.	Symbol	I/O	Function
21	VREF	O	Reference voltage output.
22	EQADJ	I/O	Equalizer center frequency setting pin.
23	3TADJ	I/O	BPF3T center frequency setting pin.
24	Vcc	-	Power supply.
25	WBLADJ	I/O	BPF22 center frequency setting pin.
26	TE	O	Tracking error signal output.
27	CSLED	-	Connects the sled error signal LPF capacitor.
28	SE	O	Sled error signal output.
29	ADFM	O	ADIP FM signal output.
30	ADIN	I	ADIP signal comparator input.
31	ADAGC	-	Connects the ADIPAGC capacitor.
32	ADFG	O	ADIP2 binary value signal output.
33	AUX	O	13 output / temperature signal output. Switched with serial commands.
34	FE	O	Focus error signal output.
35	ABCD	O	Reflection light quantity signal output for the main beam servo detector.
36	BOTM	O	RF/ABCD bottom hold signal output.
37	PEAK	O	Peak hold signal output for the RF/ABCD signals.
38	RF	O	RF equalizer output.
39	RFAGC	-	Connects the RFAGC capacitor.
40	AGCI	I	RFAGC input.
41	COMPO	O	User comparator output.
42	COMPP	I	User comparator non-inverted input.
43	ADDC	I/O	Connects the capacitor for ADIP amplifier feedback circuit.
44	OPO	O	User operational amplifier output.
45	OPN	I	User operational amplifier inverted input.
46	RFO	O	RF amplifier output. Eye pattern checkpoint.
47	MORFI	I	Input of the groove RF signal with AC coupling.
48	MORFO	O	Groove RF signal output.

■ CXD2662R (IC350) : DSP

1.Pin layout

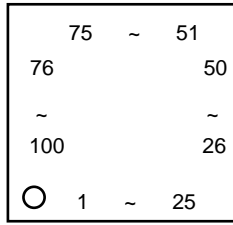

2.Block diagram

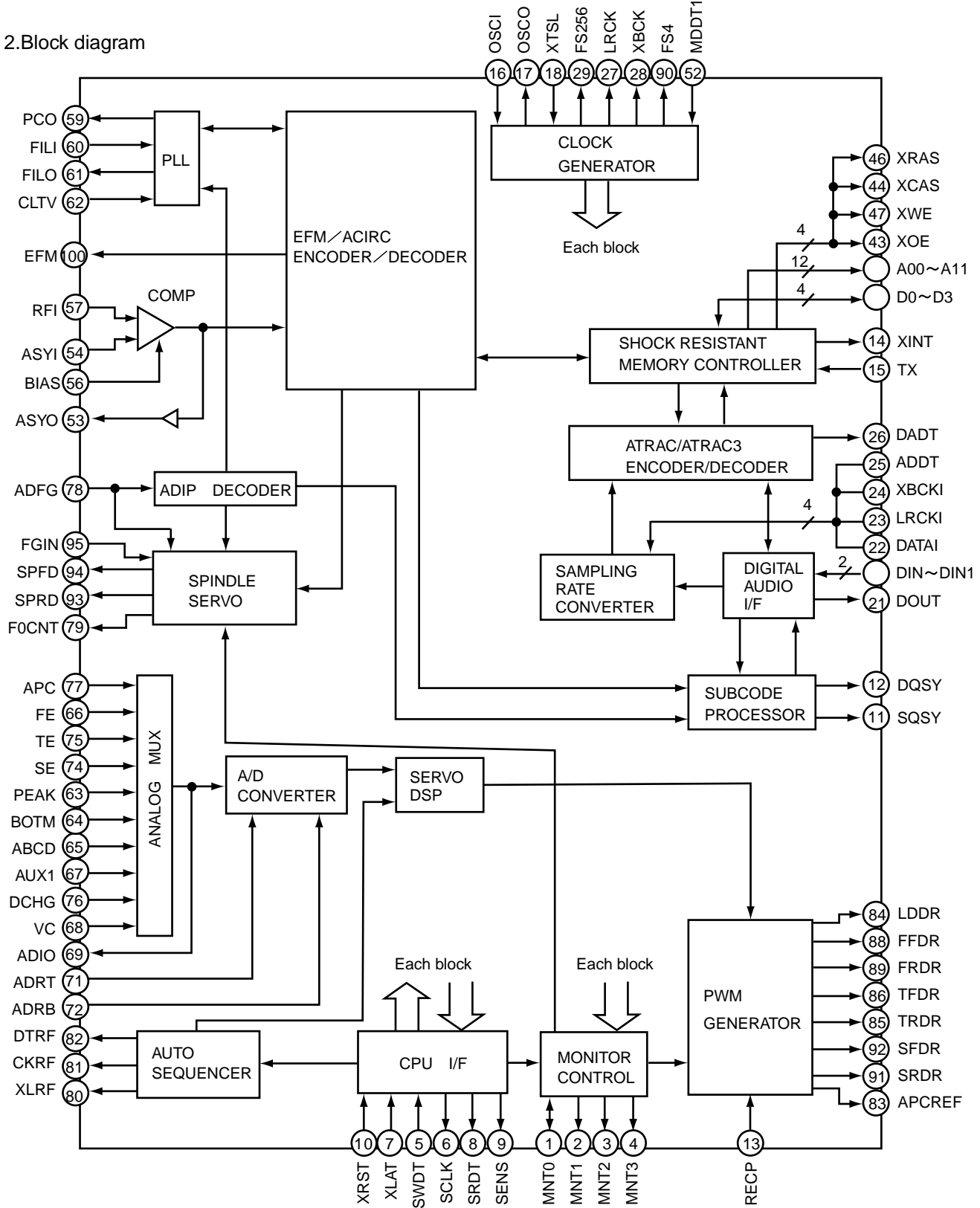

3.Pin function

Pin No.	Symbol	I/O	Function
1	MNT0	I/O	Monitor output.
2	MNT1	O	Monitor output.
3	MNT2	O	Monitor output.
4	MNT3	O	Monitor output.
5	SWDT	I	Data input for microcomputer serial interface.
6	SCLK	I	Shift clock input for microcomputer serial interface.
7	XLAT	I	Latch input for microcomputer serial interface.Latched at the falling edge.
8	SRDT	O	Data output for microcomputer serial interface.
9	SENS	O	Outputs the internal status corresponding to the microcomputer serial interface address.
10	XRST	I	Reset input. Low : reset
11	SQSY	O	Disc subcode Q sync / ADIP sync output.
12	DQSY	O	Subcode Q sync output in U-bit CD or MD format when the Digital In source is CD or MD.
13	RECP	I	Laser power switching input. High : recording power ; low ; playback power
14	XINT	O	Interruption request output. Low when the interruption status occurs.
15	TX	I	Enable signal input for recoding data output. High : enabled
16	OSCI	I	Crystal oscillation circuit input.
17	OSCO	O	Crystal oscillation circuit output. (inverted output ofthe OSCI pin)
18	XTSL	I	OSCI input frequency switching. XTSL1(command) = low and XTSL = high : 512Fs (22.5792MHz) XTSL1(command) = low and XTSL = low : 1024Fs (45.1584MHz) XTSL1(command) = high : 2048Fs (90.3168MHz)
19	DIN0	I	Digital audio interface signal input 1.
20	DIN1	I	Digital audio interface signal input 2.
21	DOUT	O	Digital audio interface signal output.
22	DATAI	I	Test pin. Connect to GND.
23	LRCKI	I	Test pin. Connect to GND.
24	XBCKI	I	Test pin. Connect to GND.
25	ADDT	I	Data input from A / D converter.
26	DADT	O	REC monitor output / decoded audio data output.
27	LRCK	O	LA clock (44.1kHz) output to the external audio block.
28	XBCK	O	Bit clock (2.8224kHz) output to the external audio block.
29	FS256	O	256Fs output.
30	DVDD	-	Digital power supply.
31	A03	O	External DRAM address output.
32	A02	O	External DRAM address output.
33	A01	O	External DRAM address output.
34	A00	O	External DRAM address output.
35	A10	O	External DRAM address output.
36	A04	O	External DRAM address output.
37	A05	O	External DRAM address output.
38	A06	O	External DRAM address output.
39	A07	O	External DRAM address output.
40	A08	O	External DRAM address output.
41	A11	O	External DRAM address output.
42	DVSS	-	Digital ground.
43	XOE	O	External DRAM output enable.

Pin No.	Symbol	I/O	Function
44	XCAS	O	External DRAM CAS output.
45	A09	O	External DRAM address output.
46	XRAS	O	External DRAM RAS output.
47	XWE	O	External DRAM write enable.
48	D1	I/O	External DRAM data bus.
49	D0	I/O	External DRAM data bus.
50	D2	I/O	External DRAM data bus.
51	D3	I/O	External DRAM data bus.
52	MDDTI	I	MD-DATA mode 1 switching input. (Low : normal mode ; high : MD-DATA mode 1)
53	ASYO	O	Playback EFM full-swing output. (Low : vss ; jigh : Vdd)
54	ASYI	I	Playback EFM comparator slice voltage input.
55	AVDD	-	Analog power supply.
56	BIAS	I	Playback EFM comparator bias current input.
57	RFI	I	Playback EFM RE signal input.
58	AVSS	-	Analog ground.
59	PCO	O	Phase comparison output for master PLL of playback digital PLL and recording EFM PLL.
60	FILI	I	Filter input for master PLL of playback digital PLL and recording EFM PLL.
61	FILO	O	Filter output for master PLL of playback digital PLL and recording EFM PLL.
62	CLTV	I	Internal VCO control voltage input for master PLL of playback digital EFM PLL and recording EFM PLL.
63	PEAK	I	Peak hold signal input for quantity of light.
64	BOTM	I	Bottom hold signal input for quantity of light.
65	ABCD	I	Signal input for quantity of light.
66	FE	I	Focus error signal input.
67	AUXI	I	Auxillary input 1.
68	VC	I	Center voltage input.
69	ADIO	I	Monitor output for A / D converter input signal.
70	AVDD	-	Analog power supply.
71	ADRT	I	Voltage input for the upper limit of the A / D converter operating range.
72	ADRB	I	Voltage input for the lower limit of the A / D converter operating range.
73	AVSS	-	Analog ground.
74	SE	I	Sled error signal input.
75	TE	I	Tracking error signal input.
76	DCHG	I	Connect to the low-impedance power supply.
77	APC	I	Error signal input for laser digital APC.
78	ADFG	I	ADIP binary FM signal (22.05 ± 1kHz) input.
79	F0CNT	O	CXA2523 current source setting output.
80	XLRF	O	CXA2523 control latch output. Latched at the falling edge.
81	CKRF	O	CXA2523 control shift clock output.
82	DTRF	O	CXA2523 control data output.
83	APCREF	O	Reference PWM output for laser APC.
84	LDDR	O	PWM output for laser digital APC.
85	TRDR	O	Tracking servo drive PWM output. (-)
86	TFDR	O	Tracking servo drive PWM output. (+)
87	DVDD	-	Digital power supply.
88	FFDR	O	Focus servo drive PWM output. (+)
89	FRDR	O	Focus servo drive PWM output. (-)
90	FS4	O	4Fs output. (176.4kHz)

Pin No.	Symbol	I/O	Function
91	SRDR	O	Sled servo drive PWM output. (-)
92	SFDR	O	Sled servo drive PWM output. (+)
93	SPRD	O	Spindle servo drive output. (PWM (-) or polarity)
94	SPFD	O	Spindle servo drive output. (PWM (+) or PWM absolute value)
95	FGIN	I	Spindle CAV servo FG input.
96	TEST1	I	Test pin. Connect to GND.
97	TEST2	I	Test pin. Connect to GND.
98	TEST3	I	Test pin. Connect to GND.
99	DVSS	-	Digital ground.
100	EFMO	O	Low when playback ; EFM (encoded data) output when recording.

■ **TC4066BP / N / (IC673) : Switch**

1.Pin layout & block diagram

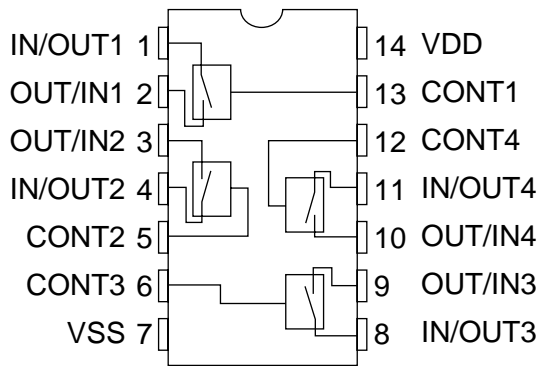

2.The truth circuit

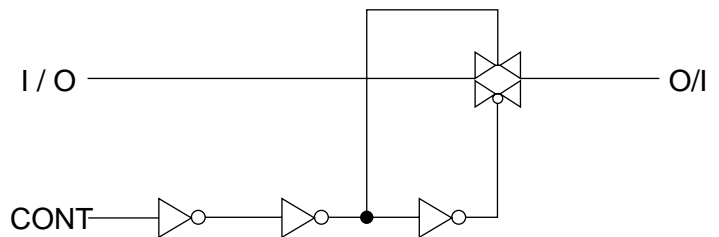

■ **TC74HC02AP (IC674) : 2ch Nor gate**

1.Pin layout & block diagram

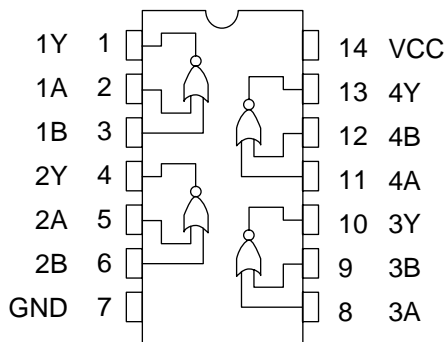

2.The truth value table

A	B	Y
L	L	H
L	H	L
H	L	L
H	H	L

■ HD6432345A15FA (IC500) : MD servo control

1.Pin layout

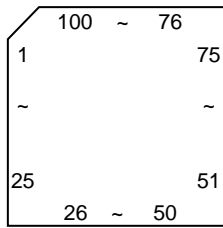

2.Pin function (1 / 2)

PIN No.	I/O	Symbol	Function
1	I	DO	Data input for EEPROM.
2	O	DI	Data input for EEPROM.
3	O	SCL	Clock output for EEPROM.
4	O	CS	Chip select for EEPROM 1.
5	-	STSRDY	Non connected.
6	-	NC	Non connected.
7	-	VSS	Ground
8	O	STATUS	Status output for host.
9	O	SWDT	Data output to CXD2662R.
10	I	COMMAND	Command input from host.
11	I	SRDT	Data input from CXD2662R.
12	I	COMCLK	Clock input from host.
13	O	SCLK	Serial clock output to CDX2662R.
14~16	-	NC	Non connected.
17	-	POWER	Power supply.
18	-	VSS	Ground
19	O	PWAD	AD power control output.
20	O	PWDA	DA power control output.
21	O	EMPHA	Emphasis control output.
22,23	-	NC	Non connected.
24	O	MODON	High frequency ON / OFF output.
25	O	MODCHG	High frequency power select output.
26	-	NC	Non connected.
27	O	MONIDATA	Data output for debug / test mode.
28	O	MONICLK	Clock output for debug / test mode.
29	O	MONILAT	Latch output for debug / test mode.
30	O	XTSL	Input frequency select output to CXD2662R.
31	-	VSS	Ground
32	O	TX	Write data output permission to CXD2662R.
33	-	NC	Non connected.
34	O	RECP	Recording power output to CXD2662R.
35,36	-	NC	Non connected.
37	O	XRST	LSI reset output to CXD2662R.
38	I	SENS	Monitor input from CXD2662R.
39	I	XLAT	Write protect switch input.
40	-	VCC	Power supply.
41~44	I	MNT3~0	LSI monitor signal from CXD2662R.
45~48	I	CAM4*1	Mechanism position detect input.
49	-	VSS	Ground
50	O	DRVON	4ch CLV drive power save.

Pin function (HD6432345A15FA 2 / 2)

PIN No.	I/O	Symbol	Function
51	I	MPROT	Write protect switch input.
52	I	SSTOP	SLED rest position detect input.
53	I	HREF	Refrect level select switch input.
54~56	O	MMONI0~2	Test terminal.
57	I	MD0	Operation setting for CPU.
58	I	MD1	Operation setting for CPU.
59	-	MMONO3	Test terminal.
60	I	WDT0VF	Operation setting for CPU.
61	I	MD2	Operation setting for CPU.
62	I	RESET	Reset input of CPU.
63	I	NMI	Operation setting for CPU.
64	I	STBY	Operation setting for CPU.
65	-	VCC	Power supply terminal.
66	O	XTAL	X'tal OSC terminal (10MHz)
67	I	EXTL	X'tal OSC terminal (10MHz)
68	-	VSS	Ground
69	-	NC	Non connect.
70	O	MHON	Magnetic head driver ON / OFF.
71	I	CDEMP	CD emphasis input.
72	I	CDCOPY	CD Cbit input.
73	I	CDTND	CD TNO input.
74	I	SQSY	Sub code Q / A dip syne.
75	I	DQSY	Connect to CXD2662R DQSY.
76	I	XINT	Interrupter requier.
77	-	AVCC	Power supply.
78	-	VREF	Power supply.
79	I	MODESE	Mode select input.
80	I	SET1	UART select input.
81	I	SET2	DOUT ON / OFF select input.
82	I	SET3	DOUT output select input.
83~86	I	MT0~3	Monitor output select.
87	-	AVSS	Ground
88	-	VSS	Ground
89~92	I	ID0~3	Operation setting for CPU.
93	O	SVIB	Sled slectrical vibration signal.
94	O	EJECT	Loading motor control output.
95	O	LOAD	Loading motor control output.
96	O	4REC	MH driver voltage down output at low temp.
97	-	NC	Non connected.
98	-	VCC	Power supply.
99	O	DIUNL	Digital in u nlock.
100	O	NC	Non connected.

■ MN662748RPM (IC651) : Digital servo & digital signal processor

1. Pin layout

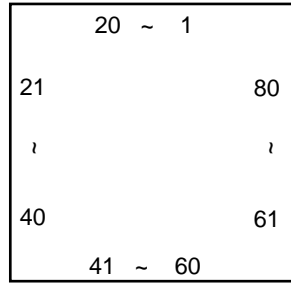

2. Block diagram

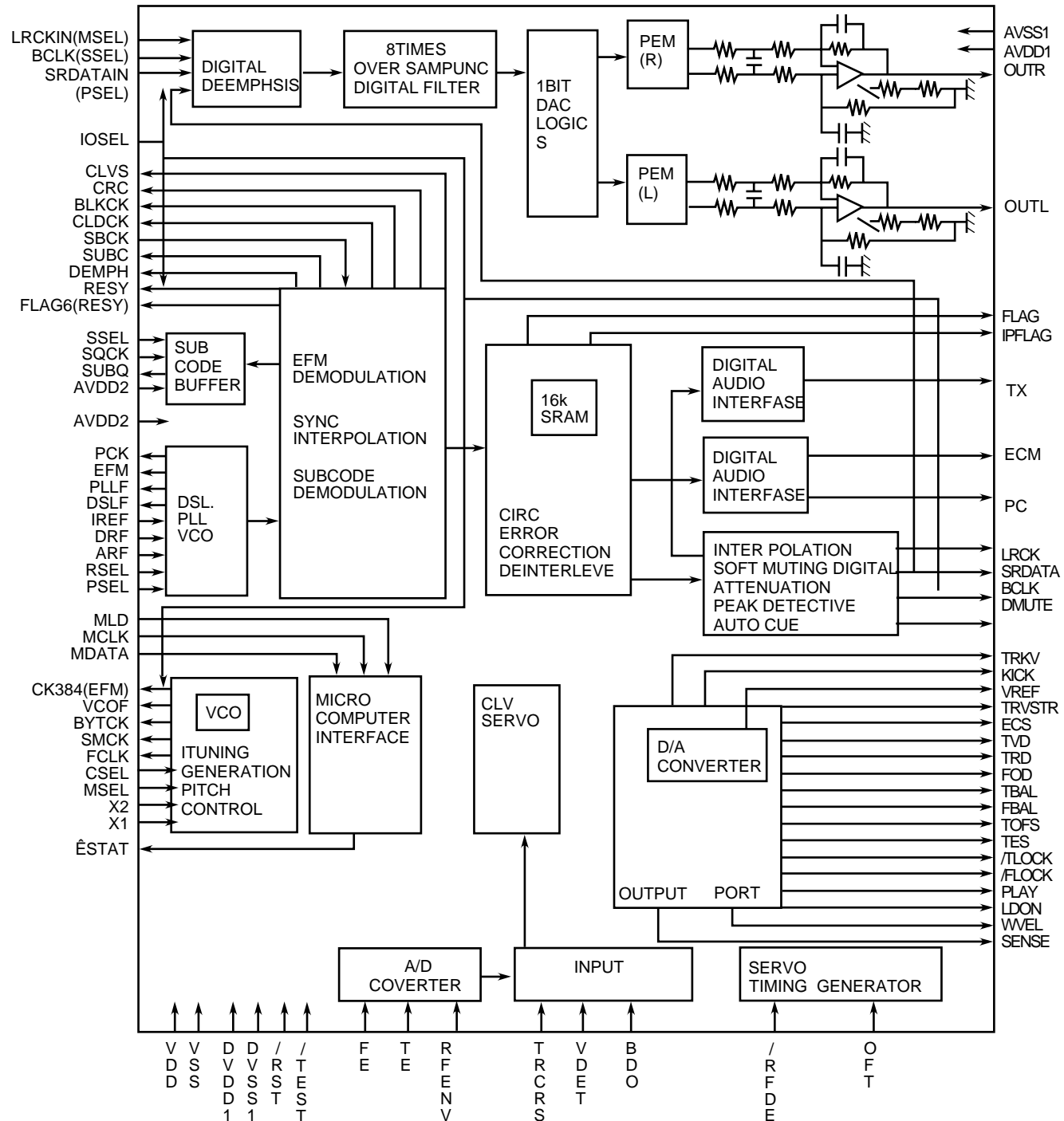

3. Pin function

Pin No.	Dymbol	I/O	Function	Pin No.	Symbol	I/O	Function
1	BCLK	O	Not used	41	TES	O	Tracking error shunt signal output (H:shunt)
2	LRCK	O	Not used	42	PLAY	—	Not used
3	SRDATA	O	Not used	43	WVEL	—	Not used
4	DVDD1	—	Power supply (Digital)	44	ARF	I	RF signal input
5	DVSS1	—	Connected to GND	45	IREF	I	Reference current input pin
6	TX	O	Digital audio interface output	46	DRF	I	Bias pin for DSL
7	MCLK	I	CPU command clock signal input (Data is latched at signal's rising point)	47	DSLFL	I/O	Loop filter pin for DSL
8	MDATA	I	CPU command data input	48	PLLF	I/O	Loop filter pin for PLL
9	MLD	I	CPU command load signal input	49	VCOF	—	Not used
10	SENSE	O	Sense signal output	50	AVDD2	—	Power supply (Analog)
11	FLOCK	O	Focus lock signal output Active :Low	51	AVSS2	—	Connected to GND (Analog)
12	TLOCK	O	Tracking lock signal output Active :Low	52	EFM	—	Not used
13	BLKCK	O	sub-code/block/clock signal output	53	PCK	—	Not used
14	SQCK	I	Outside clock for sub-code Q resister input	54	PDO	—	Not used
15	SUBQ	O	Sub-code Q -code output	55	SUBC	—	Not used
16	DMUTE	—	Connected to GND	56	SBCK	—	Not used
17	STATUS	O	Status signal (CRC,CUE,CLVS,TTSTOP,ECLV,SQOK)	57	VSS	—	Connected to GND (for X'tal oscillation circuit)
18	RST	I	Reset signal input (L:Reset)	58	X1	I	Input of 16.9344MHz X'tal oscillation circuit
19	SMCK	—	Not used	59	X2	O	Output of X'tal oscillation circuit
20	PMCK	—	Not used	60	VDD	—	Power supply (for X'tal oscillation circuit)
21	TRV	O	Traverse enforced output	61	BYTCK	—	Not used
22	TVD	O	Traverse drive output	62	CLDCK	—	Not used
23	PC	—	Not used	63	FLAG	—	Not used
24	ECM	O	Spindle motor drive signal (Enforced mode output) 3-State	64	IPPLAG	—	Not used
25	ECS	O	Spindle motor drive signal (Servo error signal output)	65	FLAG	—	Not used
26	KICK	O	Kick pulse output	66	CLVS	—	Not used
27	TRD	O	Tracking drive output	67	CRC	—	Not used
28	FOD	O	Focus drive output	68	DEMPH	—	Not used
29	VREF	I	Reference voltage input pin for D/A output block (TVD,FOD,FBA,TBAL)	69	RESY	—	Not used
30	FBAL	O	Focus Balance adjust signal output	70	IOSEL	—	pull up
31	TBAL	O	Tracking Balance adjust signal output	71	TEST	—	pull up
32	FE	I	Focus error signal input (Analog input)	72	AVDD1	—	Power supply (Digital)
33	TE	I	Tracking error signal input (Analog input)	73	OUT L	O	Lch audio output
34	RF ENV	I	RF envelope signal input (Analog input)	74	AVSS1	—	Connected to GND
35	VDET	I	Vibration detect signal input (H:detect)	75	OUT R	O	Rch audio output
36	OFT	I	Off track signal input (H:off track)	76	RSEL	—	pull up
37	TRCRS	I	Track cross signal input	77	CSEL	—	Connected to GND
38	RFDET	I	RF detect signal input (L:detect)	78	PSEL	—	Connected to GND
39	BDO	I	BDO input pin (L:detect)	79	MSEL	—	Connected to GND
40	LDON	O	Laser ON signal output (H:on)	80	SSEL	—	Pull up

■ UPD780024AGKB08 (IC251) : Unit micon

1. Pin layout

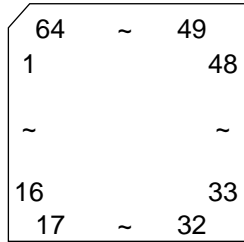

2. Pin function (1/2)

Pin No.	Symbol	I/O	Function
1	E2SCK	O	EEPROM serial clock output
2	E2SDL	O	EEPROM serial data I/O
3	MCS	O	Synchronization / asynchronous system
4	MRDY	I	Ready signal input terminal
5	ITRVP3	O	Tray play position 3
6	ITRVP2	O	Tray play position 2
7	ITRVP1	O	Tray play position 1
8	ITRYSoc	I	Sub tray open/close
9	VSSO	I	Ground
10	VDDO	I	Reference power supply voltage
11	/REST	I	Rest switch
12	CDEMP	O	CD emphasis
13	CDTNO	I	CD track No. change
14	CDCOPY	O	CD copy right or wrong
15	SUBQ	I	Sub Q data input
16	ICAMP1	O	Cam position 1
17	SQCK	O	Sub Q clock output
18	KCMND	I	Command signal input
19	MSTAT	O	Status output
20	KCLK	I	Command data clock input
21	RXDO	I	(Command in)
22	TXDO	O	(Status out)
23	ICAMP2	O	Cam position 2
24	VDD1	I	Reference power supply 1
25	AVSS	I	Ground
26	KEY1	I	key1 signal from running jig
27	KEY2	I	Key2 signal from running jig
28	TRY3CLOSE	I	Tray 3 close signal input
29	TRY3OPEN	I	Tray 3 open signal input
30	TRY2CLOSE	I	Tray 2 close signal input
31	TRY2OPEN	I	Tray 2 open signal input
32	TRY1OPEN	I	Tray 1 open signal input

2. Pin function (2/2)

Pin No.	Symbol	I/O	Function
33	TRY1CLOSE	I	Tray 1 close signal input
34	AVREF	I	Reference power supply voltage
35	AVDD	I	Reference power supply voltage
36	/RESET	I	CD reset signal input
37	XT2	O	Non connect
38	XT1	I	Reference power supply voltage
39	IC	I	No use (for Flash micon)
40	X2	O	X'tal osc output
41	X1	I	X'tal osc input
42	VSS1	I	Ground
43	FLAG	O	FLAG for C1 error
44	BLKCK	O	Sub Q block clock signal output
45	CAM_CW	O	Cam motor rotation clockwise
46	CAM_CCW	O	Cam motor rotation counter clockwise
47	ACT_CCW	O	Actuator motor rotation counter clockwise
48	ACT_CW	O	Actuator motor rotation clockwise
49	GCTRL	I	Gain select 2/4 speed
50	EQSW	I	Equalizer select 2/4 speed
51	ICAMP3	I	Cam position 3
52	ICAMP4	I	Cam position 4
53	/RESET	O	Reset signal output
54	STAT	I	Status signal input
55	/DMUTE	I	Digital mute signal input
56	/P.ON	I	Power on signal input
57	MLD	I	Command load signal input
58	MDATA	I	Command data input
59	MCLK	I	Command clock input
60	SELECT	I	Communication select signal input
61	RUNDATA	I	Running data input from running jig
62	RUNLOAD2	I	Running load 2 signal input from running jig
63	RUNLOAD1	I	Running load 1 signal input from running jig
64	RUNCLOCK	I	Running clock signal input from running jig

■ AK93C65AF-X (IC590) : EEPROM

1.Pin layout

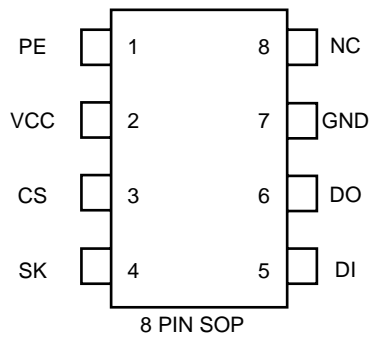

2.Block diagram

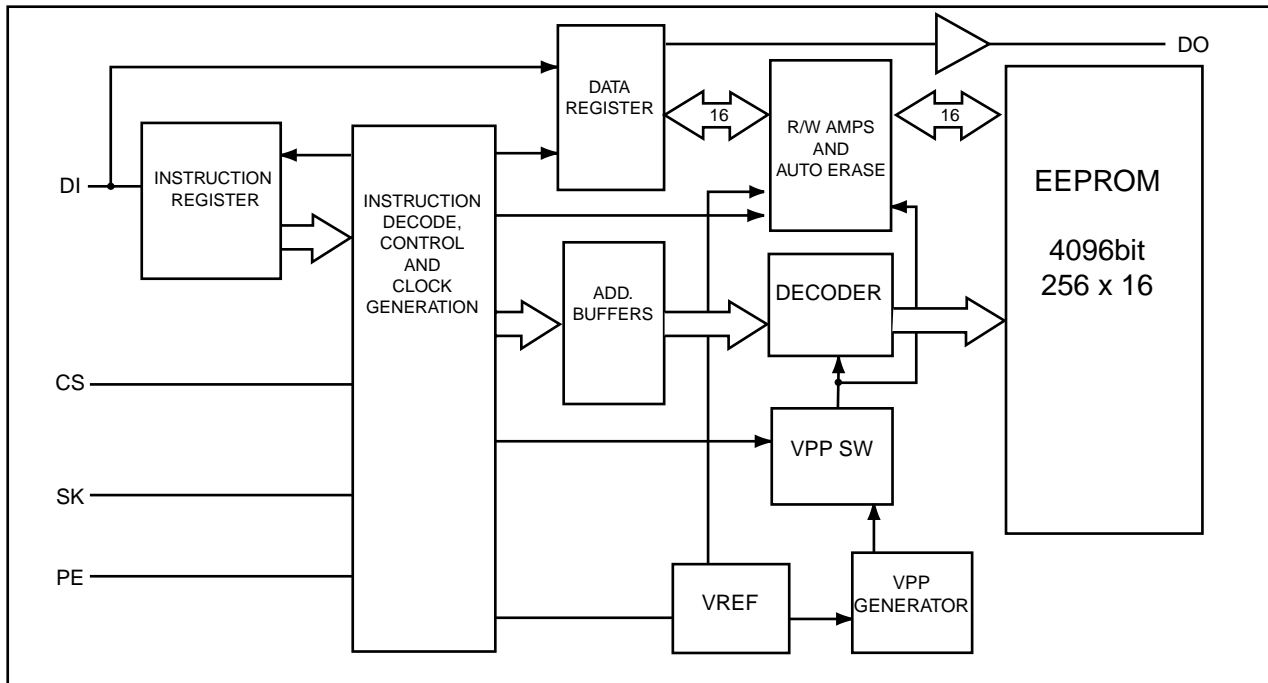

3.Pin function

Pin no.	Symbol	Function
1	PE	Program enable (With built-in pull-up resistor)
2	VCC	Power supply
3	CS	Chip selection
4	SK	Cereal clock input
5	DI	Cereal data input
6	DO	Cereal data output
7	GND	Ground
8	NC	No connection

NOTE : The pull-up resistor of the PE pin is about 2.5M Ω (VCC=5V)

■ **BD7910FV-X (IC450) : Pre driver**

1. Block diagram

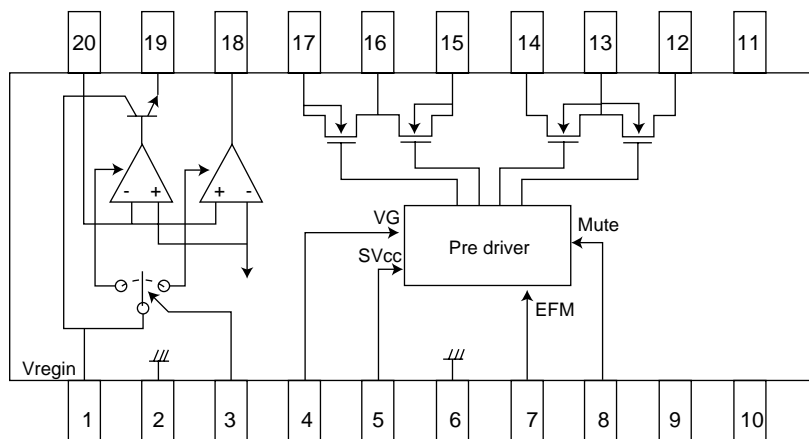

2. Pin function

Pin No.	Symbol	I/O	Function	Pin No.	Symbol	I/O	Function
1	Vreg IN	I	Regulator input and regulator power supply	11	NC	-	Non connect
				12	VOD2	O	Sync.output (Lower power MOS,drain)
2	Reg GN	-	Regulator GND	13	VSS	-	"H"bridge GND (Lower power MOS,source)
3	NC	-	Non connect	14	VOD1	O	Sync.output (Lower power MOS,drain)
4	VG	I	Voltage input for power MOS drive	15	VOS1	O	Source output (Upper power MOS,source)
5	SVCC	O	EFM high level output voltage	16	VDD	-	"H" bridge power supply terminal (Upper power MOS,source)
6	PDGND	-	Pre-driver GND				
7	EFM	I	EFM signal input	17	VOS2	O	Source output (Upper power MOS,source)
8	MUTE	I	Mute control (Low active)	18	Reg DRV	O	External PNP drive output for regulator
9	NC	O	Non connctet	19	Reg OUT	O	Reglator output (Emitter follower output)
10	NC	O	Non connect	20	Reg NF	-	Regulator feedback terminal

■ BR24C01AFV-W-X (IC201) : EEPROM

1.Pin layout

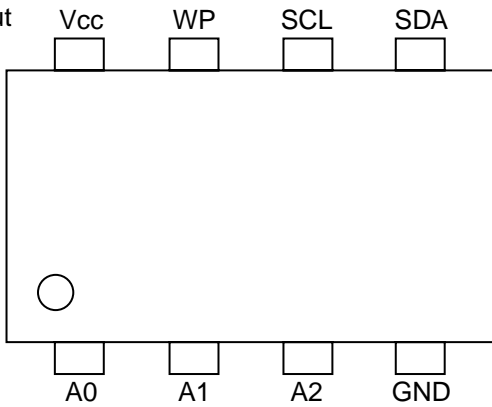

2.Block diagram

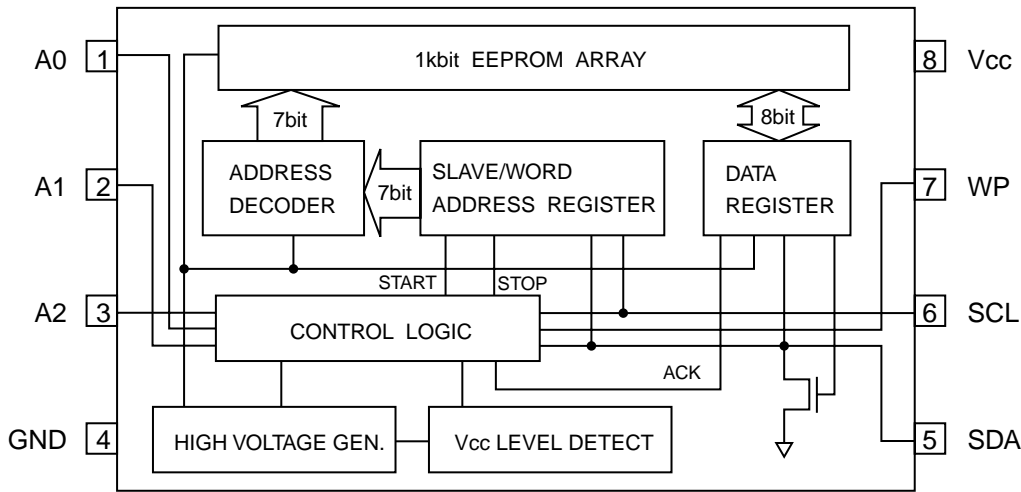

3.Pin function

Pin name	I/O	Function
Vcc	-	Power supply
GND	-	Ground (0v)
A0,A1,A2	IN	Slave address set
SCL	IN	Serial clock input
SDA	IN / OUT	Slave and word address, serial data input, serial data output *1
WP	IN	Write protect input

*1 An open drain output requires a pull-up resistor.

■ HY51V17400CT-60 (IC390) : DRAM

1.Pin layout

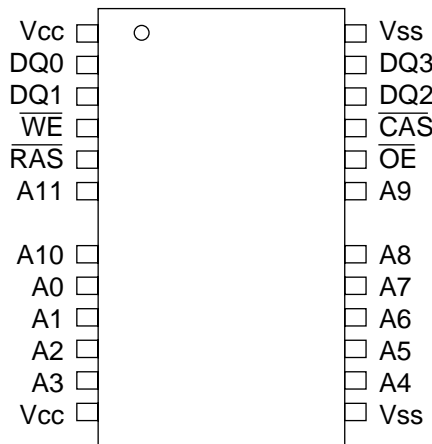

2.Pin function

Pin Name	Parameter
/RAS	Row Address Strobe
/CAS	Column Address Strobe
/WE	Write Enable
/OE	Output Enable
A0~A11	Address Input (4K Refresh Product)
A0~A10	Address Input (2K Refresh Product)
DQ0~DQ3	Data In/Out
Vcc	Power (3.3V)
Vss	Ground
NC	No Connection

3.Block diagram

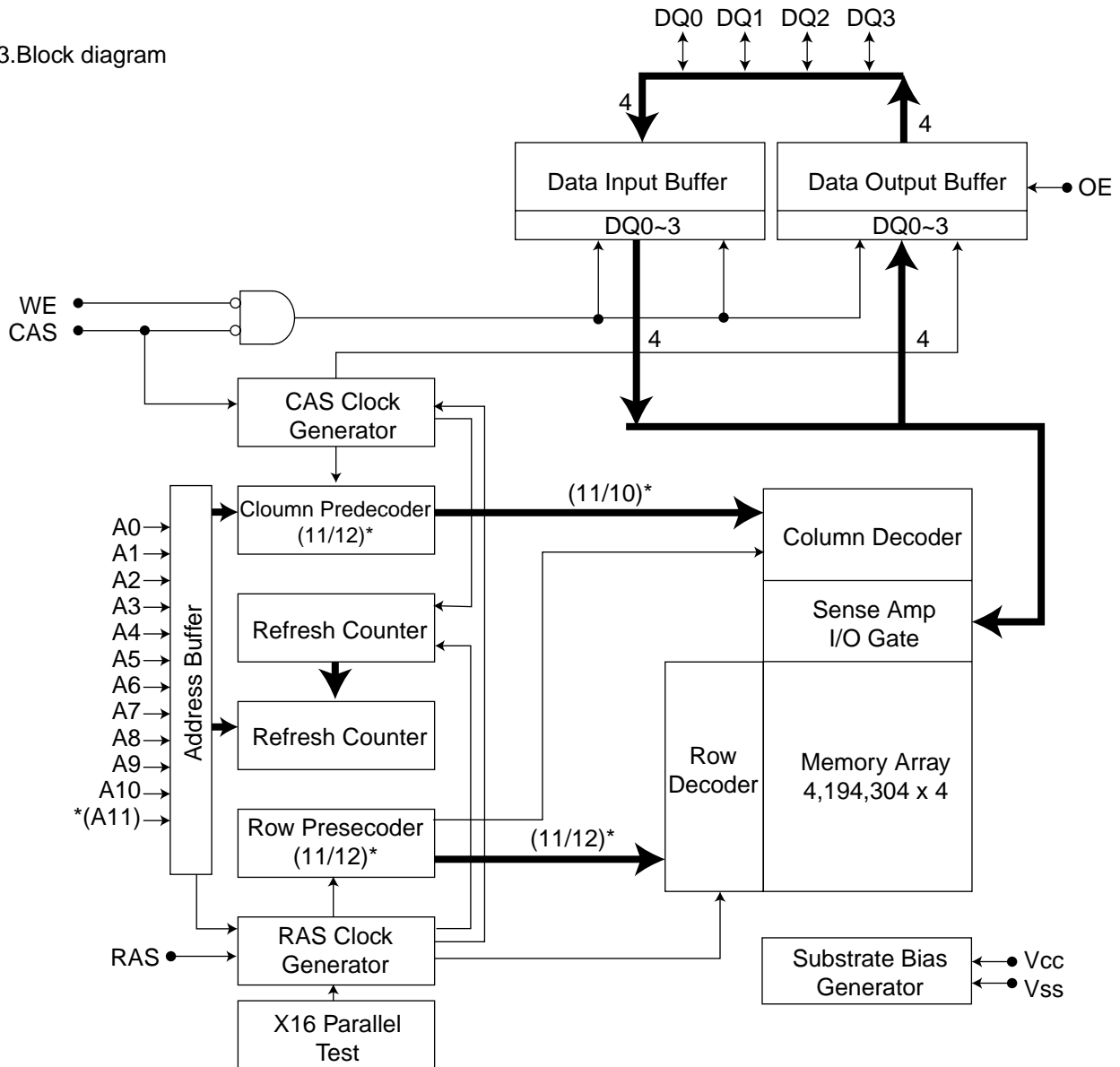

■ LA6541-X (IC801) : Servo driver

1. Pin Layout & block diagram

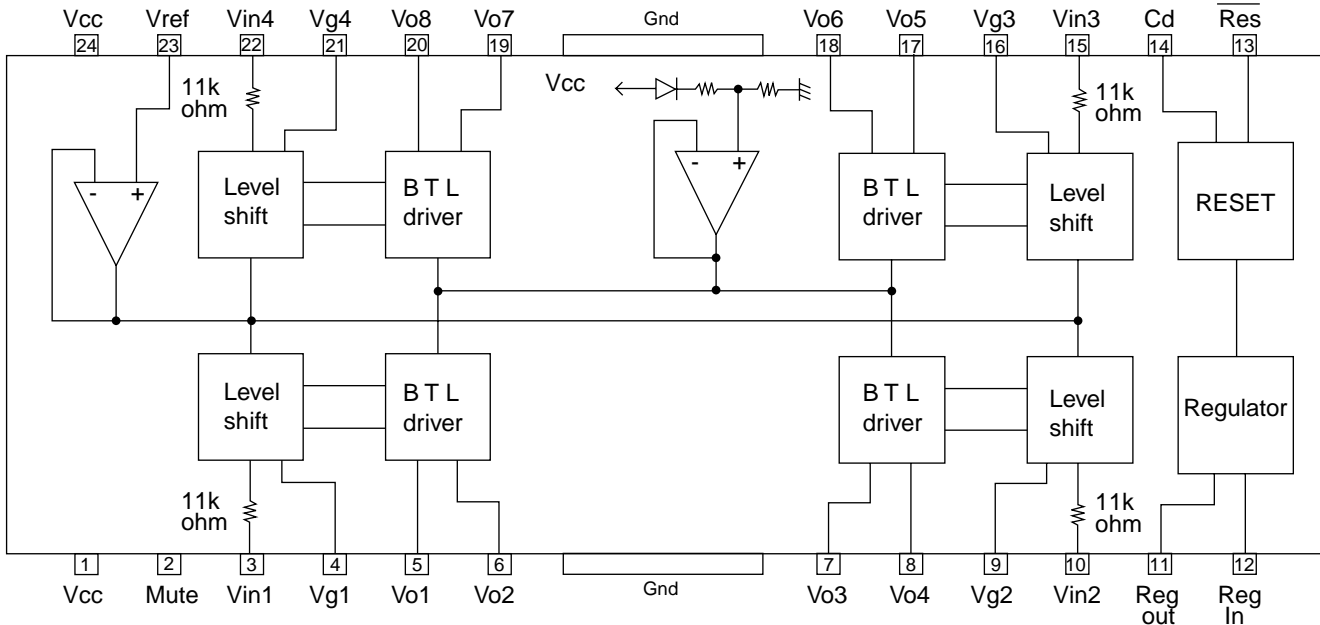

2. Pin function

Pin No.	Symbol	Function
1	Vcc	Power supply (Shorted to pin 24)
2	Mute	All BTL amplifier outputs ON/OFF
3	Vin1	BTL AMP 1 input pin
4	Vg1	BTL AMP 1 input pin (For gain adjustment)
5	Vo1	BTL AMP 1 input pin (Non inverting side)
6	Vo2	BTL AMP 1 input pin (Inverting side)
7	Vo3	BTL AMP 2 input pin (Inverting side)
8	Vo4	BTL AMP 2 input pin (Non inverting side)
9	Vg2	BTL AMP 2 input pin (For gain adjustment)
10	Vin2	BTL AMP 2 input pin
11	Reg Out	External transistor collector (PNP) connection. 5V power supply output
12	Reg In	External transistor (PNP) base connection
13	Res	Reset output
14	Cd	Reset output delay time setting (Capacitor connected externally)
15	Vin3	BTL AMP 3 input pin
16	Vg3	BTL AMP 3 input pin (For gain adjustment)
17	Vo5	BTL AMP 3 output pin (Non inverting side)
18	Vo6	BTL AMP 3 output pin (Inverting side)
19	Vo7	BTL AMP 4 output pin (Inverting side)
20	Vo8	BTL AMP 4 output pin (Non inverting side)
21	Vg4	BTL AMP 4 output pin (For gain adjustment)
22	Vin4	BTL AMP 4 output pin
23	Vref	Level shift circuit's reference voltage application
24	Vcc	Power supply (Shorted to pin 1)

■ M63008FP-X (IC410) : 5ch Actuator driver

1.Pin layout

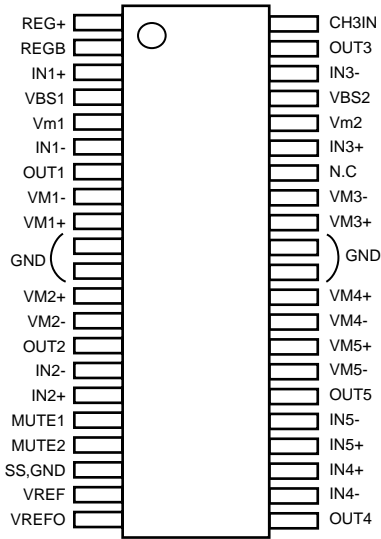

2.Block diagram

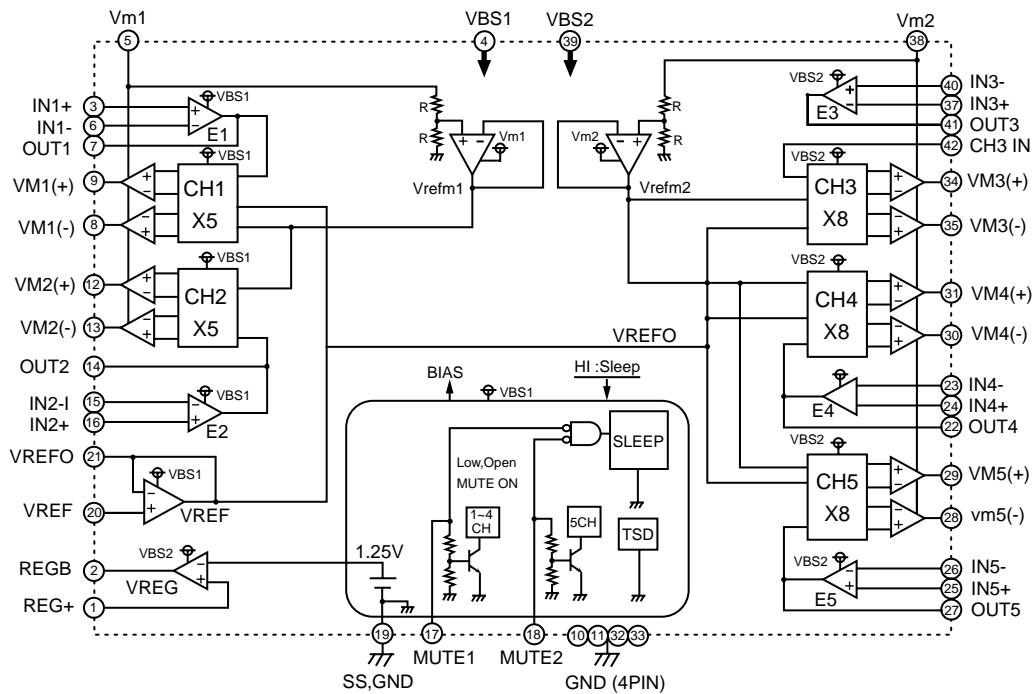

■ MN101C12GDW (IC851): Panel micon

1. Pin layout

75	~	51
76		50
~		~
100		26
○ 1	~	25

2. Pin function

Pin No.	Symbol	I/O	Function
1	-	-	Connect to ground.
2	LEVEL Lch	I	Input terminal.
3	LEVEL Rch	I	Input terminal.
4~9	-	-	Connect to ground.
10	A / D Power	-	A / D Ref. voltage.
11	Vdd	-	Ref. voltage.
12	8.38MHz	I	OSC frequency input terminal.
13	8.38MHz	O	OSC frequency output terminal.
14	GND	-	Connect to ground.
15	-	-	Connect to ground.
16	-	-	Non use.
17~19	-	-	Connect to ground.
20	-	-	Connect to ground.
21	comm sysreq	O	System CPU require signal output terminal.
22	LED STBY red	O	Stand by LED (RED) output terminal.
23	LED POWER green	O	Power LED (GREEN) output terminal.
24	-	-	Connect to ground.
25	-	-	Connect to ground.
26	comm panereq	I	Panel CPU require signal input terminal.
27~32	-	-	Connect to ground.
33	comm reset	I	Reset signal input terminal.
34	-	-	Connect to ground.
35	-	-	Connect to ground.
36	LED MD REC	O	MD (RED) output terminal.
37~41	-	-	Connect to ground.
42	comm out	O	Commor signal output terminal.
43	comm in	I	Commor signal input terminal.
44	comm clock	I	Commor clock signal input terminal.
45~57	-	-	Connect to ground.
58	LCD WE	O	Write enable output terminal.
59	LCD RE	O	Read enable output terminal.
60	LCD CS1	O	Chip select output terminal.
61	-	-	Connect to ground.
62	-	-	Connect to ground.
63	LCD AO	O	Data select signal output terminal.
64	LCD RESET	O	LCD reset signal output terminal.
65~72	-	-	Connect to ground.
73	LCD LEDdimmer	O	Dimmer control terminal.
74~78	-	-	Connect to ground.
79~86	LCD D7~D0	O	Pata bus signal output terminal.
87~94	-	-	Connect to ground.
95	DVASS	-	Connect to ground.
96	-	-	Non use.
97	LED RED	O	Red LED control terminal.
98	LED GREEN	O	Green LED control terminar.
99	LED BLUE	O	Blue LED control terminal.
100	DAVdd	-	Ref. voltage.

■ NJM4580D (IC672) : LPF, Mic and H.phone Amp.

1. Terminal layout

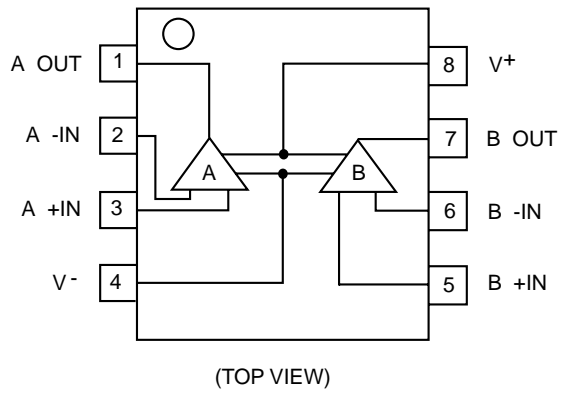

2. Block diagram

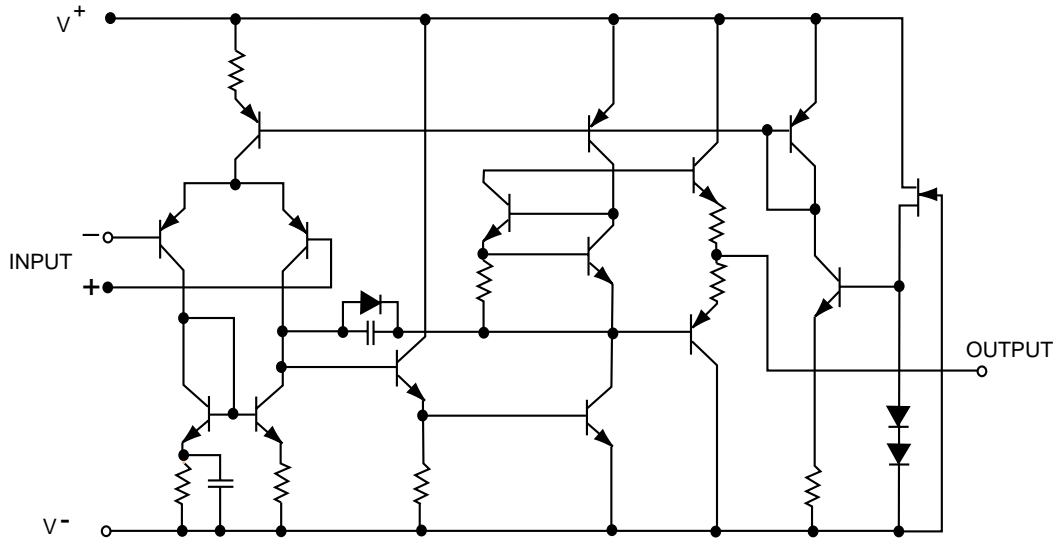

■STK402-030 (IC301) : Power amp.

1.Pin layout

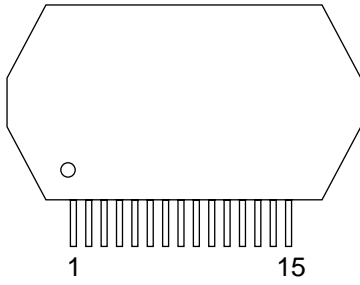

2.Block diagram

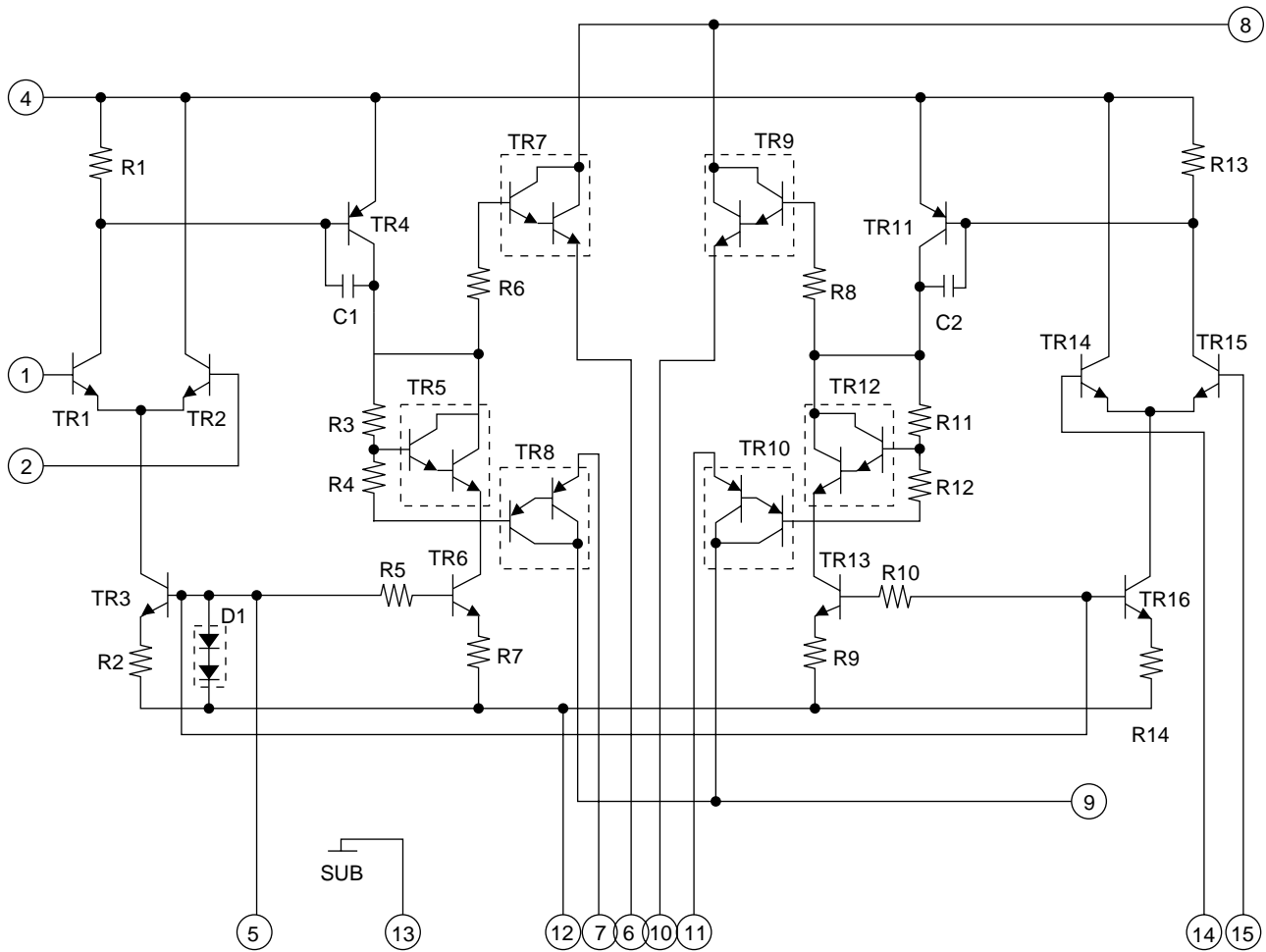

■ TC7S08F-W (IC340) : Buffer

1. Pin layout

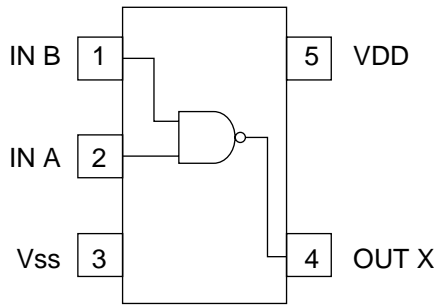

2. Block diagram

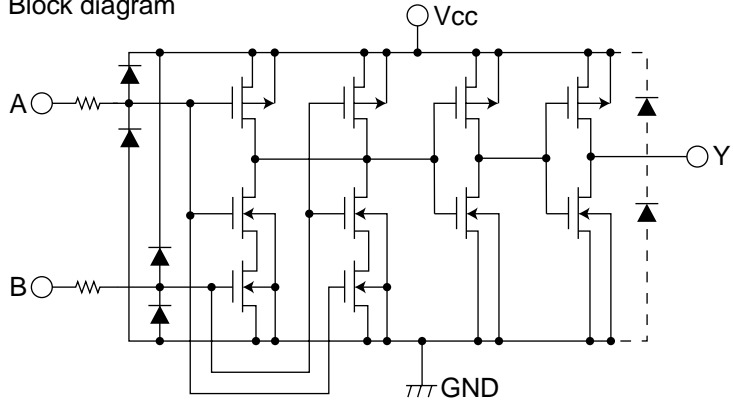

■ TC7S32F-X (IC603) : NAND gata

1.Pin layout

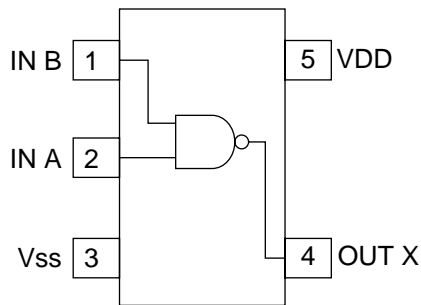

2.Block diagram

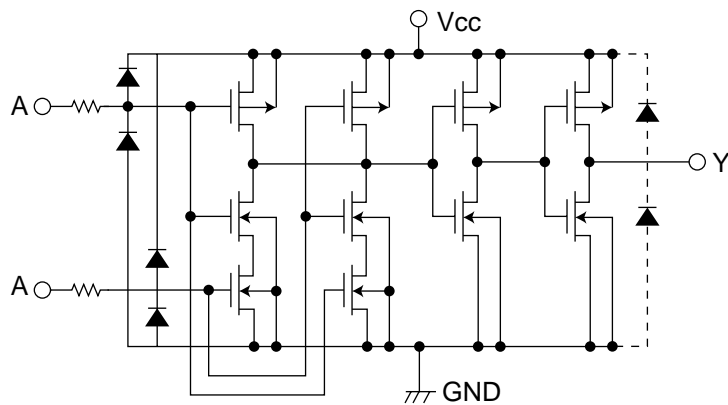

■ LB1641 (IC851,IC852) : DC motor driver

1. Pin layout

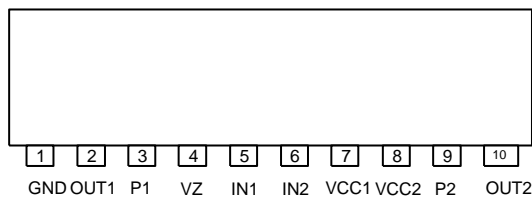

2. Pin function

Input		Output		Mode
IN1	IN2	OUT1	OUT2	
0	0	0	0	Brake
1	0	1	0	CLOCKWISE
0	1	0	1	COUNTER-CLOCKWISE
1	1	0	0	Brake

■ NJM4580E-W (IC652): Ope. amp.

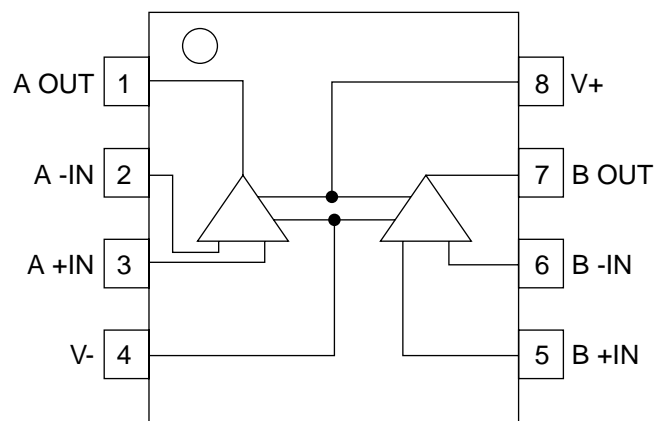

■ TDA7439 (IC671) : Control volume

1.Pin layout

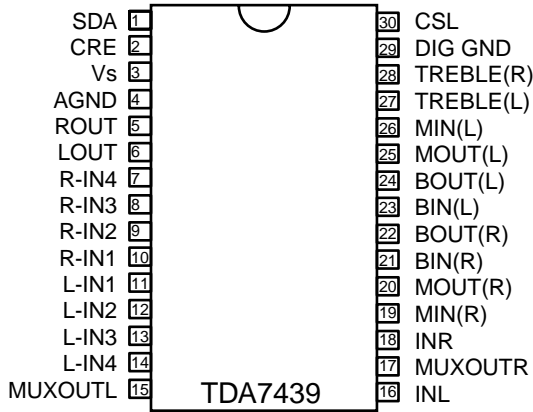

2.Block diagram

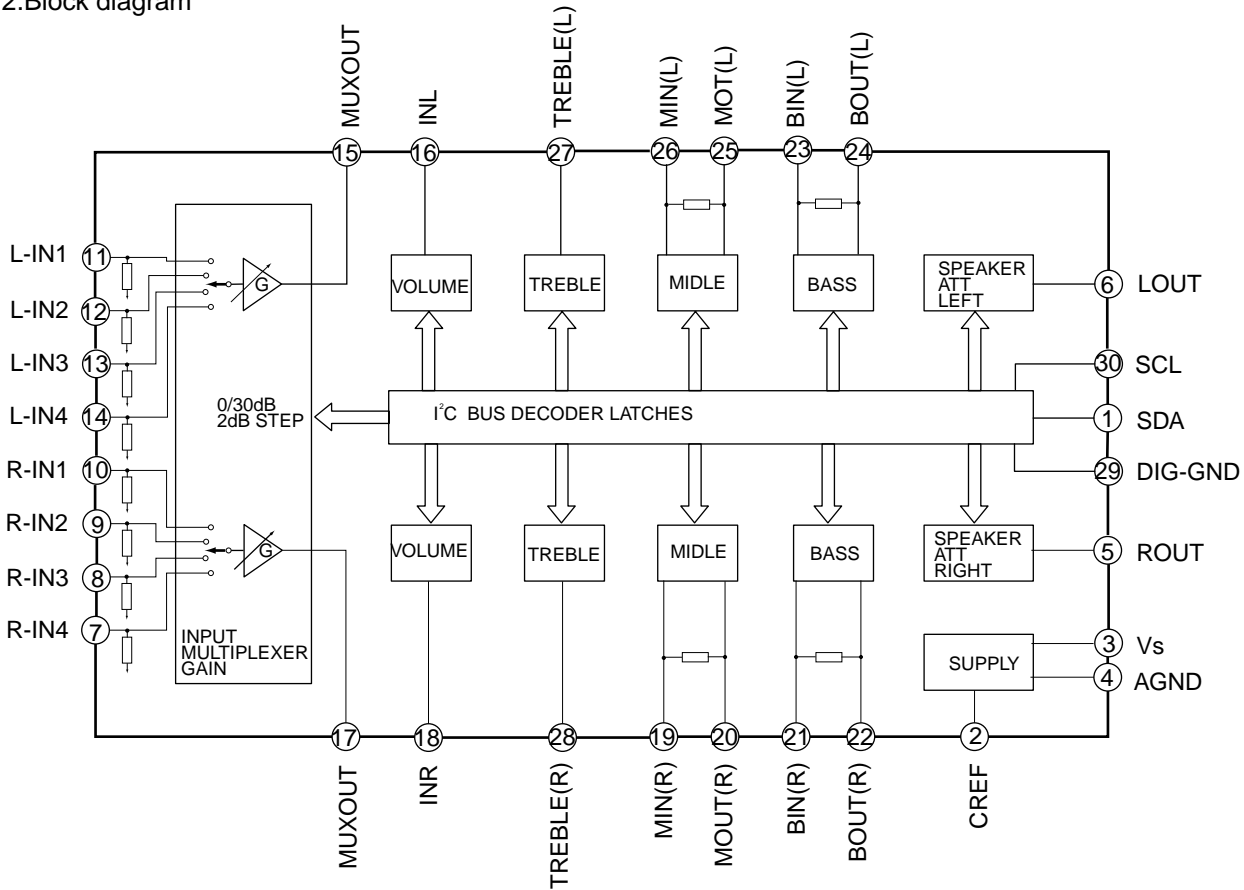

■ TK11140SC-W (IC485) : Regulator

1.Pin layout

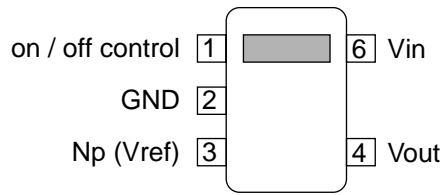

2.Block diagram

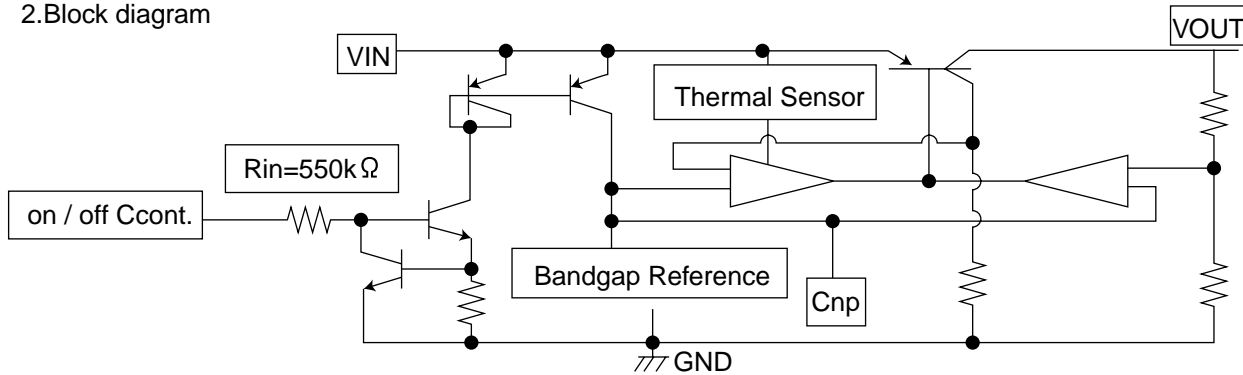

■ UPC393G2-W (IC602) : Voltage comparator

1.Pin layout

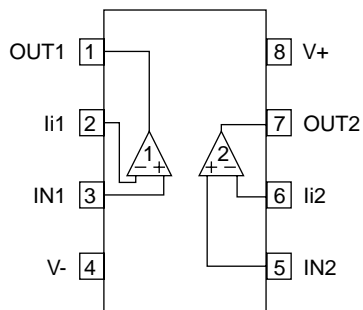

2.Block diagram

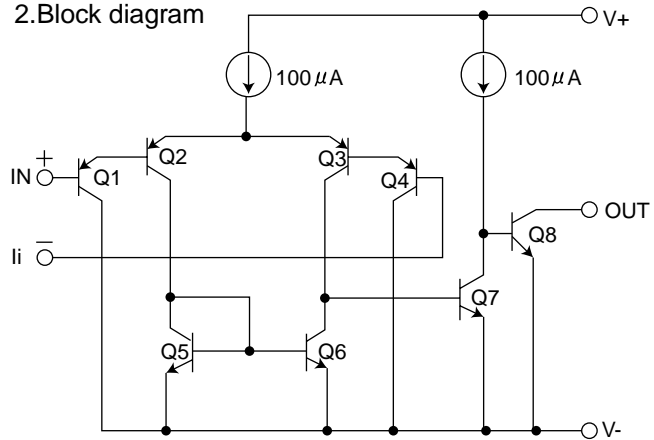

■ XC62ER3602M-X (IC400) : Regulator

1.Pin layout

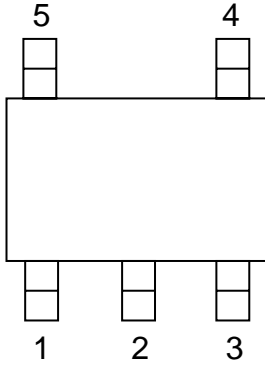

2.Block diagram

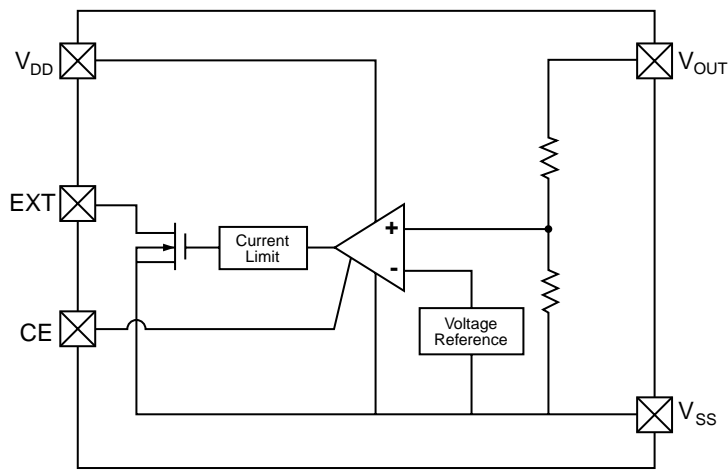

3.Pin function

Pin No.	Symbol	Function
1	V_{SS}	GND
2	V_{IN}	Power supply input
3	V_{OUT}	Regulator output
4	EXT	Base current control terminal
5	CE	Chip enable

CA-MXS6MDR
SP-MXS6MD

JVC

VICTOR COMPANY OF JAPAN, LIMITED
AUDIO & COMMUNICATION BUSINESS DIVISION
PERSONAL & MOBILE NETWORK B.U 10-1,1Chome,Ohwatari-machi,Maebashi-city,371-8543,Japan